

LVL WOOD MULLION

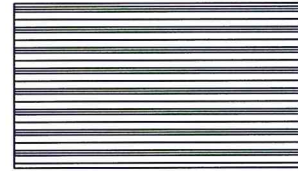

2" x 3.5" LVL WOOD MULLION

GENERAL NOTES:

1. This product has been evaluated and is in compliance with the 5th Edition (2014) Florida Building Code (FBC) structural requirements excluding the "High Velocity Hurricane Zone".
2. When used in areas requiring wind borne debris protection this product complies with Section 1609.1.2 of the FBC and does not require an impact resistant covering. This product meets missile level "D" and excludes Wind Zone 4 as defined in ASTM E 1996 and Section 1609.1.2.2 of the FBC.
3. Wood bucks by others, must be anchored properly to transfer loads to the structure and be reviewed by the Building Official.
4. Mullion anchor embedment to base material shall be beyond wall dressing or stucco.
5. Separate product approvals for each glazing product used with these mullions must be submitted along with this mullion product approval.
6. Anchoring of each glazing product to the mullion shall be as shown in each individual glazing product approval.
7. Any conditions not covered in this evaluation are subject to separate Engineering evaluation.
8. Mullion design pressure rating, see load rating table sheets 2 - 6 of this drawing.
9. The design pressure rating of the assembly shall be the lesser of the load capacity of the mullion as determined using this approval or the design pressure rating of the individual glazing products used.

TABLE OF CONTENTS

SHEET #	DESCRIPTION
1	Typical Elevations & General Notes
2	Mullion Load Table: Anchor Clip B4 (Concrete Screws)
3	Mullion Load Table: Anchor Clip B4 (Wood Screws)
4	Mullion Load Table: Anchor Clip B1 (Concrete Screws)
5	Mullion Load Table: Anchor Clip B1 (Wood Screws)
6	Mullion Load Table: Anchor Plate (Wood/Concrete Screws)
7	Anchor Clip B4: Anchoring Details
8	Anchor Clip B1: Anchoring Details
9	Mullion Anchor Plate: Anchoring Details



TYPICAL MULLION CONFIGURATIONS

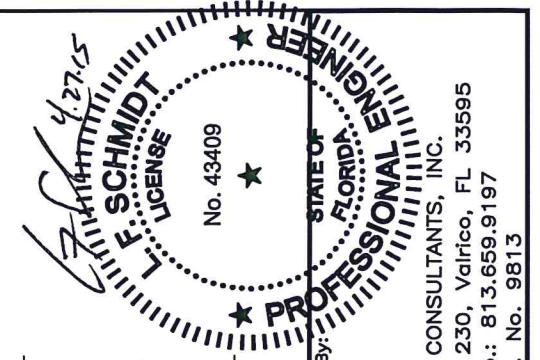

Documents Prepared By:
 Lyndon F. Schmidt
 P.E. No. 43409
 RW BUILDING CONSULTANTS, INC.
 P.O. Box 230, Vairico, FL 33595
 Phone No.: 813.659.9197
 FBPE C.A. No. 9813

PRODUCT: STRUCTURAL MULLION
 PART OR ASSEMBLY: TYPICAL ELEVATION & GENERAL NOTES

NO.	DATE	REVISIONS	LFS	BY
1	4/17/15	UPDATE TO 5TH ED. (2014) FBC		

DATE: 02/28/12
 SCALE: NTS
 DWG. BY: EW
 CHK. BY: LFS
 DRAWING NO.: FL-15267.5
 SHEET 1 OF 9

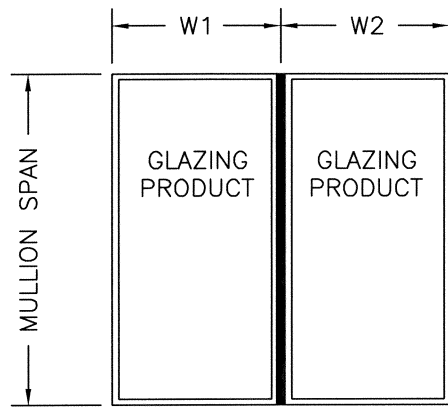

$$\text{TRIBUTARY WIDTH} = \frac{W1 + W2}{2}$$

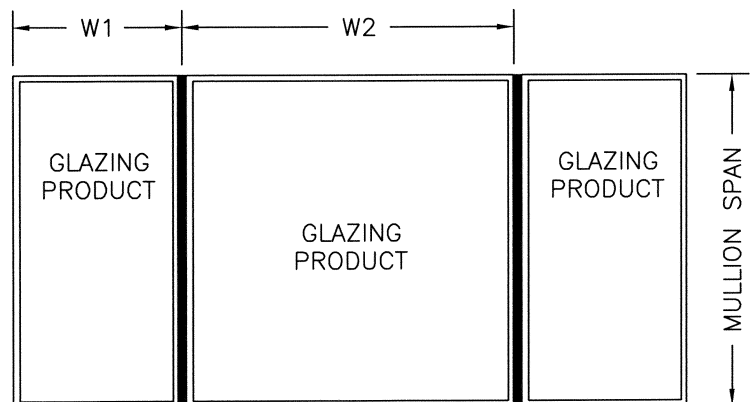

CONCRETE SCREW	2" x 3.5" LVL STRUCTURAL BEAM MULLION LOAD TABLE (PSF) - ANCHOR CLIP B4													
	TRIBUTARY WIDTH													
	24.0"	28.0"	30.0"	32.0"	34.0"	36.0"	38.0"	40.0"	42.0"	44.0"	46.0"	48.0"	50.0"	
120.0"	15.37	NA	NA	NA	NA	NA	NA	NA	NA	NA	NA	NA	NA	
116.0"	17.05	NA	NA	NA	NA	NA	NA	NA	NA	NA	NA	NA	NA	
112.0"	18.98	16.44	15.42	NA	NA	NA	NA	NA	NA	NA	NA	NA	NA	
108.0"	21.22	18.38	17.25	16.26	15.39	NA	NA	NA	NA	NA	NA	NA	NA	
104.0"	23.82	20.65	19.38	18.27	17.30	16.43	15.66	NA	NA	NA	NA	NA	NA	
100.0"	26.87	23.30	21.88	20.63	19.53	18.56	17.69	16.91	16.20	15.56	NA	NA	NA	
96.0"	30.45	26.43	24.82	23.41	22.17	21.07	20.09	19.21	18.41	17.69	17.03	16.43	15.87	
92.0"	34.71	30.14	28.31	26.72	25.31	24.06	22.95	21.95	21.04	20.23	19.48	18.79	18.15	
88.0"	39.80	34.58	32.50	30.67	29.07	27.65	26.38	25.23	24.20	23.27	22.41	21.61	20.87	
84.0"	45.94	39.94	37.55	35.45	33.61	31.98	30.52	29.21	28.03	26.95	25.95	25.02	24.15	
80.0"	53.41	46.47	43.70	41.28	39.15	37.27	35.58	34.07	32.69	31.42	30.25	29.16	28.14	
76.0"	62.59	54.50	51.28	48.46	45.98	43.79	41.83	40.05	38.42	36.92	35.53	34.24	33.04	
72.0"	73.99	64.50	60.71	57.41	54.50	51.93	49.60	47.48	45.53	43.74	42.08	40.54	39.12	
68.0"	80.79	71.81	68.29	65.25	62.62	60.25	58.06	56.02	54.13	52.31	50.31	48.46	46.74	
64.0"	87.00	77.55	73.86	70.69	67.86	65.25	62.83	60.59	58.50	56.55	54.73	53.02	51.41	
60.0"	94.25	84.30	80.43	77.00	73.86	70.96	68.29	65.80	63.49	61.34	59.33	57.45	55.68	
56.0"	102.82	92.33	88.13	84.30	80.79	77.55	74.57	71.81	69.24	66.86	64.63	62.54	60.59	
52.0"	113.10	101.85	97.12	92.80	88.85	85.22	81.88	78.79	75.93	73.26	70.78	68.46	66.29	
48.0"	125.67	113.10	107.71	102.82	98.35	94.25	90.48	87.00	83.78	80.79	78.00	75.40	72.97	
44.0"	141.01	126.55	120.37	114.77	109.67	105.01	100.72	96.77	93.12	89.73	86.58	83.65	80.91	
40.0"	150.00	142.86	135.72	129.26	123.38	118.02	113.10	108.58	104.40	100.53	96.94	93.60	90.48	
36.0"	150.00	150.00	150.00	147.12	140.28	134.04	128.34	123.10	118.27	113.81	109.67	105.82	102.24	
32.0"	150.00	150.00	150.00	150.00	150.00	150.00	147.52	141.38	135.72	130.50	125.67	121.18	117.00	
28.0"	150.00	150.00	150.00	150.00	150.00	150.00	150.00	150.00	150.00	150.00	146.33	141.01	136.06	
24.0"	150.00	150.00	150.00	150.00	150.00	150.00	150.00	150.00	150.00	150.00	150.00	150.00	150.00	
20.0"	150.00	150.00	150.00	150.00	150.00	150.00	150.00	150.00	150.00	150.00	150.00	150.00	150.00	

INSTRUCTIONS FOR USE OF THE MULLION LOAD TABLE:

1. DETERMINE THE DESIGN LOAD REQUIREMENT PER CHAPTER 16 OF THE FBC FOR THE PARTICULAR OPENING.
2. FOR THE PARTICULAR OPENING, DETERMINE THE TRIBUTARY WIDTH AND MULLION SPAN. REFERENCE THE SKETCHES ON THIS SHEET FOR MULLION SPAN AND TRIBUTARY WIDTH DETERMINATION.
3. IN THE FIRST COLUMN OF THE TABLE, LOCATE THE MULLION SPAN. IN THE FIRST ROW OF THE TABLE, LOCATE THE TRIBUTARY WIDTH. AT THE INTERSECTION OF THE ROW CONTAINING THE MULLION SPAN AND THE COLUMN CONTAINING THE TRIBUTARY WIDTH, READ THE MULLION LOAD RATING GIVEN IN PSF. THE MULLION LOAD RATING MUST BE EQUAL TO OR GREATER THAN THE DESIGN LOAD REQUIREMENT DETERMINED IN STEP 1 ABOVE.

Documents Prepared By: *LFS*
 Lyndon F. Schmidt
 P.E. No. 43409

RW
 BUILDING CONSULTANTS, INC.
 P.O. Box 230, Valrico, FL 33595
 Phone No.: 813.659.9197
 FBPE C.A. No. 9813

PRODUCT:	STRUCTURAL MULLION
PART OR ASSEMBLY:	MULLION LOAD TABLE: ANCHOR CLIP B4 (CONCRETE SCREWS)
DATE:	02/28/12
SCALE:	NTS
DWG. BY:	EW
CHK. BY:	LFS
DRAWING NO.:	FL-15267.5
SHEET	2 OF 9

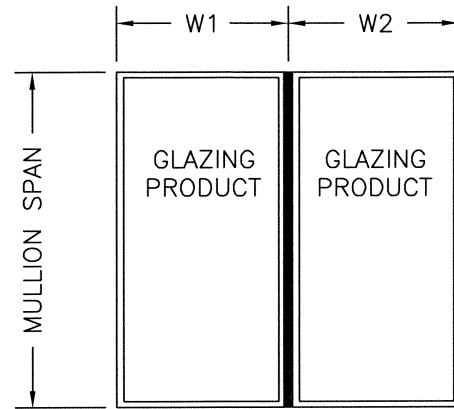

$$\text{TRIBUTARY WIDTH} = \frac{W1 + W2}{2}$$

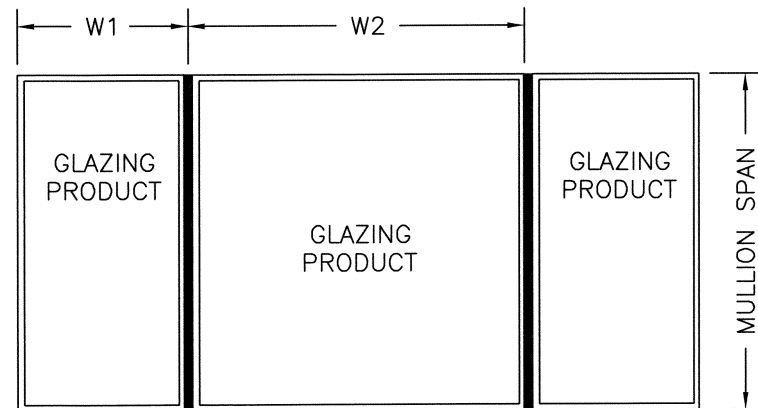

WOOD SCREW	2" x 3.5" LVL STRUCTURAL BEAM MULLION LOAD TABLE (PSF) - ANCHOR CLIP B4													
	TRIBUTARY WIDTH													
	24.0"	28.0"	32.0"	32.0"	34.0"	36.0"	38.0"	40.0"	42.0"	44.0"	46.0"	48.0"	50.0"	
120.0"	15.37	NA	NA	NA	NA	NA	NA	NA	NA	NA	NA	NA	NA	
116.0"	17.05	NA	NA	NA	NA	NA	NA	NA	NA	NA	NA	NA	NA	
112.0"	18.98	16.44	NA	NA	NA	NA	NA	NA	NA	NA	NA	NA	NA	
108.0"	21.22	18.38	16.26	16.26	15.39	NA	NA	NA	NA	NA	NA	NA	NA	
104.0"	23.82	20.65	18.27	18.27	17.30	16.43	15.66	NA	NA	NA	NA	NA	NA	
100.0"	26.87	23.30	20.63	20.63	19.53	18.56	17.69	16.91	16.20	15.56	NA	NA	NA	
96.0"	30.45	26.43	23.41	23.41	22.17	21.07	20.09	19.21	18.41	17.69	17.03	16.43	15.87	
92.0"	34.71	30.14	26.72	26.72	25.31	24.06	22.95	21.95	21.04	20.23	19.48	18.79	18.15	
88.0"	39.80	34.58	30.67	30.67	29.07	27.65	26.38	25.23	24.20	23.27	22.41	21.61	20.87	
84.0"	45.94	39.94	35.45	35.45	33.61	31.98	30.52	29.21	28.03	26.95	25.95	25.02	24.15	
80.0"	53.41	46.47	41.28	41.28	39.15	37.27	35.58	34.07	32.69	31.42	30.25	29.16	28.14	
76.0"	62.59	54.50	48.46	48.46	45.98	43.79	41.83	40.05	38.42	36.92	35.53	34.24	33.04	
72.0"	73.99	64.50	57.41	57.41	54.50	51.93	49.60	47.48	45.53	43.74	42.08	40.54	39.12	
68.0"	80.79	71.81	65.25	65.25	62.62	60.25	58.06	56.02	54.13	52.31	50.31	48.46	46.74	
64.0"	87.00	77.55	70.69	70.69	67.86	65.25	62.83	60.59	58.50	56.55	54.73	53.02	51.41	
60.0"	94.25	84.30	77.00	77.00	73.86	70.96	68.29	65.80	63.49	61.34	59.33	57.45	55.68	
56.0"	102.82	92.33	84.30	84.30	80.79	77.55	74.57	71.81	69.24	66.86	64.63	62.54	60.59	
52.0"	113.10	101.85	92.80	92.80	88.85	85.22	81.88	78.79	75.93	73.26	70.78	68.46	66.29	
48.0"	125.67	113.10	102.82	102.82	98.35	94.25	90.48	87.00	83.78	80.79	78.00	75.40	72.97	
44.0"	141.01	126.55	114.77	114.77	109.67	105.01	100.72	96.77	93.12	89.73	86.58	83.65	80.91	
40.0"	150.00	142.86	129.26	129.26	123.38	118.02	113.10	108.58	104.40	100.53	96.94	93.60	90.48	
36.0"	150.00	150.00	147.12	147.12	140.28	134.04	128.34	123.10	118.27	113.81	109.67	105.82	102.24	
32.0"	150.00	150.00	150.00	150.00	150.00	150.00	147.52	141.38	135.72	130.50	125.67	121.18	117.00	
28.0"	150.00	150.00	150.00	150.00	150.00	150.00	150.00	150.00	150.00	150.00	146.33	141.01	136.06	
24.0"	150.00	150.00	150.00	150.00	150.00	150.00	150.00	150.00	150.00	150.00	150.00	150.00	150.00	
20.0"	150.00	150.00	150.00	150.00	150.00	150.00	150.00	150.00	150.00	150.00	150.00	150.00	150.00	

INSTRUCTIONS FOR USE OF THE MULLION LOAD TABLE:

1. DETERMINE THE DESIGN LOAD REQUIREMENT PER CHAPTER 16 OF THE FBC FOR THE PARTICULAR OPENING.
2. FOR THE PARTICULAR OPENING, DETERMINE THE TRIBUTARY WIDTH AND MULLION SPAN. REFERENCE THE SKETCHES ON THIS SHEET FOR MULLION SPAN AND TRIBUTARY WIDTH DETERMINATION.
3. IN THE FIRST COLUMN OF THE TABLE, LOCATE THE MULLION SPAN. IN THE FIRST ROW OF THE TABLE, LOCATE THE TRIBUTARY WIDTH. AT THE INTERSECTION OF THE ROW CONTAINING THE MULLION SPAN AND THE COLUMN CONTAINING THE TRIBUTARY WIDTH, READ THE MULLION LOAD RATING GIVEN IN PSF. THE MULLION LOAD RATING MUST BE EQUAL TO OR GREATER THAN THE DESIGN LOAD REQUIREMENT DETERMINED IN STEP 1 ABOVE.

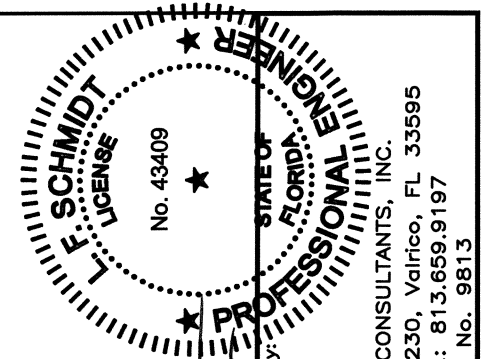

Documents Prepared By: Lyndon F. Schmidt
P.E. No. 43409

PROFESSIONAL ENGINEER
BUILDING CONSULTANTS, INC.
P.O. Box 230, Valrico, FL 33595
Phone No.: 813.659.9197
FBPE C.A. No. 9813

PRODUCT: STRUCTURAL MULLION
PART OR ASSEMBLY: MULLION LOAD TABLE: ANCHOR CLIP B4 (WOOD SCREWS)

NO.	DATE	DESCRIPTION
1	4/17/15	UPDATE TO 5TH ED. (2014) FBC

DATE: 02/28/12
SCALE: NTS
DWG. BY: EW
CHK. BY: LFS
DRAWING NO.: FL-15267.5
SHEET 3 OF 9

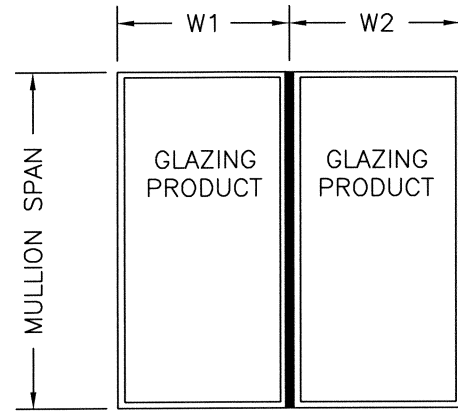

$$\text{TRIBUTARY WIDTH} = \frac{W1 + W2}{2}$$

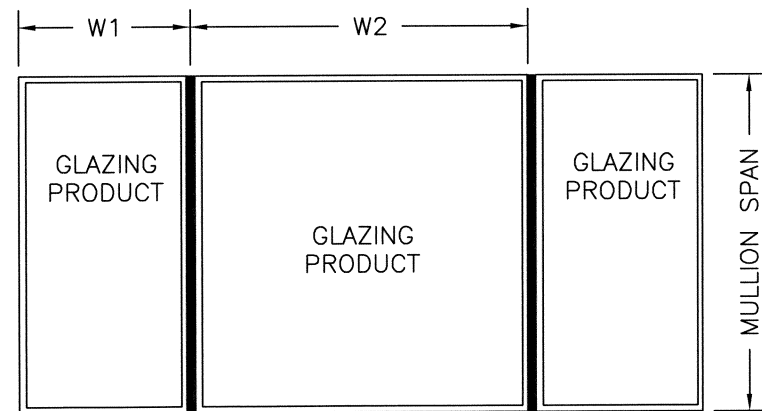

CONCRETE SCREW		2" x 3.5" LVL STRUCTURAL BEAM MULLION LOAD TABLE (PSF) - ANCHOR CLIP B1												
		TRIBUTARY WIDTH												
		24.0"	28.0"	30.0"	32.0"	34.0"	36.0"	38.0"	40.0"	42.0"	44.0"	46.0"	48.0"	50.0"
MULLION SPAN	120.0"	15.37	NA	NA	NA	NA	NA	NA	NA	NA	NA	NA	NA	NA
	116.0"	17.05	NA	NA	NA	NA	NA	NA	NA	NA	NA	NA	NA	NA
	112.0"	18.98	16.44	15.42	NA	NA	NA	NA	NA	NA	NA	NA	NA	NA
	108.0"	21.22	18.38	17.25	16.26	15.39	NA	NA	NA	NA	NA	NA	NA	NA
	104.0"	23.82	20.65	19.38	18.27	17.30	16.43	15.66	NA	NA	NA	NA	NA	NA
	100.0"	26.87	23.30	21.88	20.63	19.53	18.56	17.69	16.91	16.20	15.56	NA	NA	NA
	96.0"	30.45	26.43	24.82	23.41	22.17	21.07	20.09	19.21	18.41	17.69	17.03	16.43	15.87
	92.0"	34.71	30.14	28.31	26.72	25.31	24.06	22.95	21.95	21.04	20.23	19.48	18.79	18.15
	88.0"	39.80	34.58	32.50	30.67	29.07	27.65	26.38	25.23	24.20	23.27	22.41	21.61	20.87
	84.0"	45.94	39.94	37.55	35.45	33.61	31.98	30.52	29.21	28.03	26.95	25.95	25.02	24.15
	80.0"	53.41	46.47	43.70	41.28	39.15	37.27	35.58	34.07	32.69	31.42	30.25	29.16	28.14
	76.0"	62.59	54.50	51.28	48.46	45.98	43.79	41.83	40.05	38.42	36.92	35.53	34.24	33.04
	72.0"	73.99	64.50	60.71	57.41	54.50	51.93	49.60	47.48	45.53	43.74	42.08	40.54	39.12
	68.0"	88.35	77.10	72.62	68.71	65.26	62.18	59.38	56.82	54.47	52.31	50.31	48.46	46.74
	64.0"	106.69	93.22	87.85	83.17	79.02	75.25	71.83	68.71	65.85	63.21	60.78	58.53	56.44
	60.0"	130.47	114.16	107.67	101.95	96.80	92.15	87.93	84.07	80.54	77.30	74.30	71.53	68.96
	56.0"	150.00	140.82	133.84	126.66	120.20	114.37	109.09	104.26	99.85	95.80	92.06	88.60	85.39
	52.0"	150.00	150.00	148.12	141.54	135.52	129.98	124.89	120.17	115.80	111.74	107.95	104.41	101.10
	48.0"	150.00	150.00	150.00	150.00	150.00	143.75	138.00	132.69	127.78	123.21	118.97	115.00	111.29
	44.0"	150.00	150.00	150.00	150.00	150.00	150.00	150.00	147.59	142.02	136.86	132.06	127.58	123.40
40.0"	150.00	150.00	150.00	150.00	150.00	150.00	150.00	150.00	150.00	150.00	147.86	142.76	138.00	
36.0"	150.00	150.00	150.00	150.00	150.00	150.00	150.00	150.00	150.00	150.00	150.00	150.00	150.00	
32.0"	150.00	150.00	150.00	150.00	150.00	150.00	150.00	150.00	150.00	150.00	150.00	150.00	150.00	
28.0"	150.00	150.00	150.00	150.00	150.00	150.00	150.00	150.00	150.00	150.00	150.00	150.00	150.00	
24.0"	150.00	150.00	150.00	150.00	150.00	150.00	150.00	150.00	150.00	150.00	150.00	150.00	150.00	
20.0"	150.00	150.00	150.00	150.00	150.00	150.00	150.00	150.00	150.00	150.00	150.00	150.00	150.00	

INSTRUCTIONS FOR USE OF THE MULLION LOAD TABLE:

1. DETERMINE THE DESIGN LOAD REQUIREMENT PER CHAPTER 16 OF THE FBC FOR THE PARTICULAR OPENING.
2. FOR THE PARTICULAR OPENING, DETERMINE THE TRIBUTARY WIDTH AND MULLION SPAN. REFERENCE THE SKETCHES ON THIS SHEET FOR MULLION SPAN AND TRIBUTARY WIDTH DETERMINATION.
3. IN THE FIRST COLUMN OF THE TABLE, LOCATE THE MULLION SPAN. IN THE FIRST ROW OF THE TABLE, LOCATE THE TRIBUTARY WIDTH. AT THE INTERSECTION OF THE ROW CONTAINING THE MULLION SPAN AND THE COLUMN CONTAINING THE TRIBUTARY WIDTH, READ THE MULLION LOAD RATING GIVEN IN PSF. THE MULLION LOAD RATING MUST BE EQUAL TO OR GREATER THAN THE DESIGN LOAD REQUIREMENT DETERMINED IN STEP 1 ABOVE.

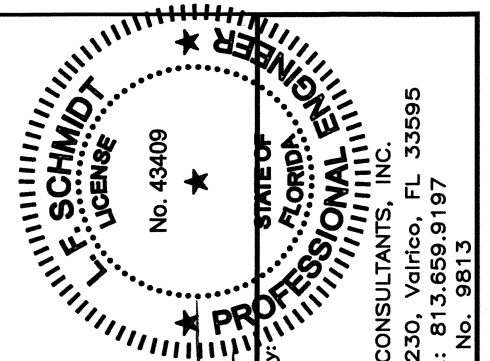

Documents Prepared By:
 Lyndon F. Schmidt
 P.E. No. 43409

RW

BUILDING CONSULTANTS, INC.
 P.O. Box 230, Valrico, FL 33595
 Phone No.: 813.659.9197
 FBPE C.A. No. 9813

PRODUCT:	STRUCTURAL MULLION
PART OR ASSEMBLY:	MULLION LOAD TABLE: ANCHOR CLIP B1 (CONCRETE SCREWS)
DATE:	02/28/12
SCALE:	NTS
DWG. BY:	EW
CHK. BY:	LFS
DRAWING NO.:	FL-15267.5
SHEET	4 OF 9

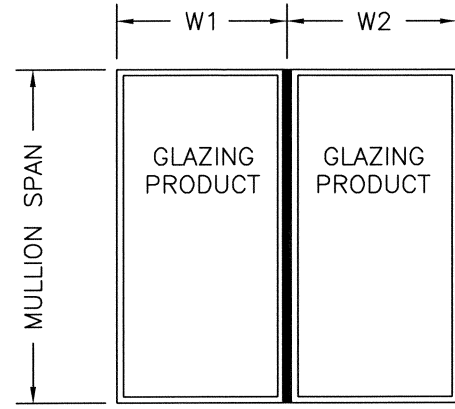

$$\text{TRIBUTARY WIDTH} = \frac{W1 + W2}{2}$$

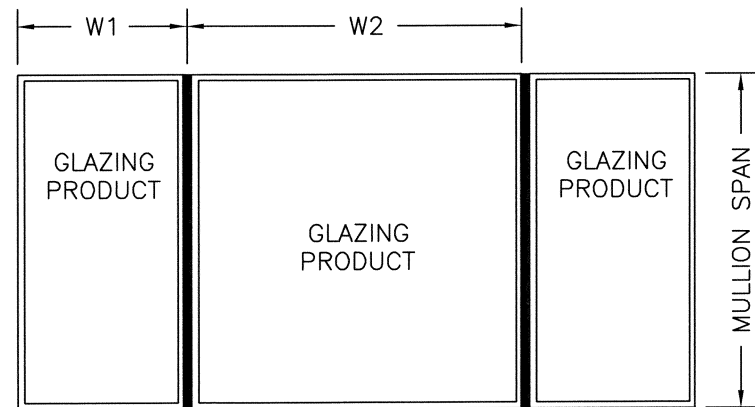

WOOD SCREW	2" x 3.5" LVL STRUCTURAL BEAM MULLION LOAD TABLE (PSF) - ANCHOR CLIP B1													
	TRIBUTARY WIDTH													
	24.0"	28.0"	30.0"	32.0"	34.0"	36.0"	38.0"	40.0"	42.0"	44.0"	46.0"	48.0"	50.0"	
120.0"	15.37	NA	NA	NA	NA	NA	NA	NA	NA	NA	NA	NA	NA	
116.0"	17.05	NA	NA	NA	NA	NA	NA	NA	NA	NA	NA	NA	NA	
112.0"	18.98	16.44	15.42	NA	NA	NA	NA	NA	NA	NA	NA	NA	NA	
108.0"	21.22	18.38	17.25	16.26	15.39	NA	NA	NA	NA	NA	NA	NA	NA	
104.0"	23.82	20.65	19.38	18.27	17.30	16.43	15.66	NA	NA	NA	NA	NA	NA	
100.0"	26.87	23.30	21.88	20.63	19.53	18.56	17.69	16.91	16.20	15.56	NA	NA	NA	
96.0"	30.45	26.43	24.82	23.41	22.17	21.07	20.09	19.21	18.41	17.69	17.03	16.43	15.87	
92.0"	34.71	30.14	28.31	26.72	25.31	24.06	22.95	21.95	21.04	20.23	19.48	18.79	18.15	
88.0"	39.80	34.58	32.50	30.67	29.07	27.65	26.38	25.23	24.20	23.27	22.41	21.61	20.87	
84.0"	45.94	39.94	37.55	35.45	33.61	31.98	30.52	29.21	28.03	26.95	25.95	25.02	24.15	
80.0"	53.41	46.47	43.70	41.28	39.15	37.27	35.58	34.07	32.69	31.42	30.25	29.16	28.14	
76.0"	62.59	54.50	51.28	48.46	45.98	43.79	41.83	40.05	38.42	36.92	35.53	34.24	33.04	
72.0"	73.99	64.50	60.71	57.41	54.50	51.93	49.60	47.48	45.53	43.74	42.08	40.54	39.12	
68.0"	88.35	77.10	72.62	68.71	65.26	62.18	59.38	56.82	54.47	52.31	50.31	48.46	46.74	
64.0"	106.69	93.22	87.85	83.17	79.02	75.25	71.83	68.71	65.85	63.21	60.78	58.53	56.44	
60.0"	130.47	114.16	107.67	101.95	96.80	92.15	87.93	84.07	80.54	77.30	74.30	71.53	68.96	
56.0"	150.00	140.82	133.84	126.66	120.20	114.37	109.09	104.26	99.85	95.80	92.06	88.60	85.39	
52.0"	150.00	150.00	148.12	141.54	135.52	129.98	124.89	120.17	115.80	111.74	107.95	104.41	101.10	
48.0"	150.00	150.00	150.00	150.00	150.00	143.75	138.00	132.69	127.78	123.21	118.97	115.00	111.29	
44.0"	150.00	150.00	150.00	150.00	150.00	150.00	150.00	147.59	142.02	136.86	132.06	127.58	123.40	
40.0"	150.00	150.00	150.00	150.00	150.00	150.00	150.00	150.00	150.00	150.00	147.86	142.76	138.00	
36.0"	150.00	150.00	150.00	150.00	150.00	150.00	150.00	150.00	150.00	150.00	150.00	150.00	150.00	
32.0"	150.00	150.00	150.00	150.00	150.00	150.00	150.00	150.00	150.00	150.00	150.00	150.00	150.00	
28.0"	150.00	150.00	150.00	150.00	150.00	150.00	150.00	150.00	150.00	150.00	150.00	150.00	150.00	
24.0"	150.00	150.00	150.00	150.00	150.00	150.00	150.00	150.00	150.00	150.00	150.00	150.00	150.00	
20.0"	150.00	150.00	150.00	150.00	150.00	150.00	150.00	150.00	150.00	150.00	150.00	150.00	150.00	

INSTRUCTIONS FOR USE OF THE MULLION LOAD TABLE:

1. DETERMINE THE DESIGN LOAD REQUIREMENT PER CHAPTER 16 OF THE FBC FOR THE PARTICULAR OPENING.
2. FOR THE PARTICULAR OPENING, DETERMINE THE TRIBUTARY WIDTH AND MULLION SPAN. REFERENCE THE SKETCHES ON THIS SHEET FOR MULLION SPAN AND TRIBUTARY WIDTH DETERMINATION.
3. IN THE FIRST COLUMN OF THE TABLE, LOCATE THE MULLION SPAN. IN THE FIRST ROW OF THE TABLE, LOCATE THE TRIBUTARY WIDTH. AT THE INTERSECTION OF THE ROW CONTAINING THE MULLION SPAN AND THE COLUMN CONTAINING THE TRIBUTARY WIDTH, READ THE MULLION LOAD RATING GIVEN IN PSF. THE MULLION LOAD RATING MUST BE EQUAL TO OR GREATER THAN THE DESIGN LOAD REQUIREMENT DETERMINED IN STEP 1 ABOVE.

Documents Prepared By: *LFS*
 Lyndon F. Schmidt
 P.E. No. 43409
 4/27/15

PROFESSIONAL ENGINEER
 BUILDING CONSULTANTS, INC.
 P.O. Box 230, Valrico, FL 33595
 Phone No.: 813.659.9197
 FBPE C.A. No. 9813

PRODUCT:	STRUCTURAL MULLION
PART OR ASSEMBLY:	MULLION LOAD TABLE: ANCHOR CLIP B1 (WOOD SCREWS)
DATE:	02/28/12
SCALE:	NTS
DWG. BY:	EW
CHK. BY:	LFS
DRAWING NO.:	FL-15267.5
SHEET	5 OF 9

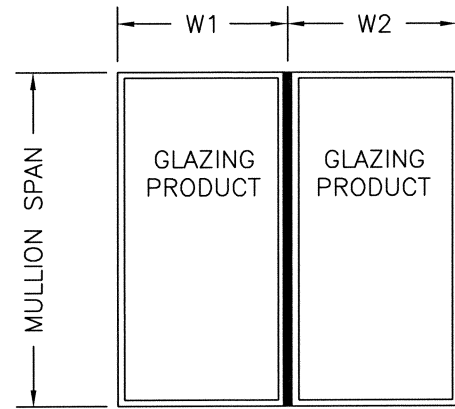

$$\text{TRIBUTARY WIDTH} = \frac{W1 + W2}{2}$$

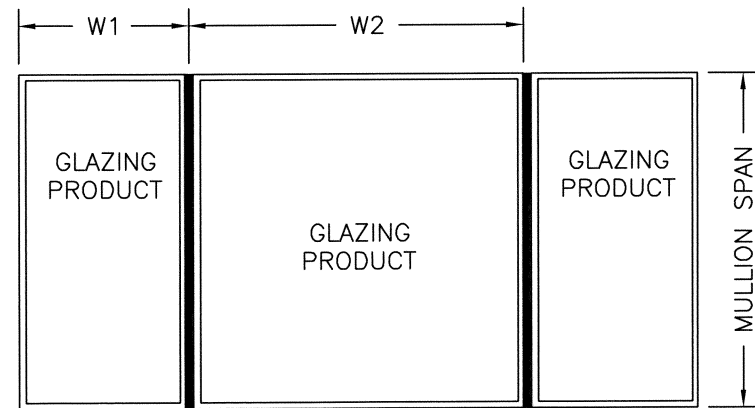

WOOD OR CONCRETE SCREW	2" x 3.5" LVL STRUCTURAL BEAM MULLION LOAD TABLE (PSF) - ANCHOR PLATE													
	TRIBUTARY WIDTH													
	24.0"	28.0"	30.0"	32.0"	34.0"	36.0"	38.0"	40.0"	42.0"	44.0"	46.0"	48.0"	50.0"	
MULLION SPAN	120.0"	15.37	NA	NA	NA	NA	NA	NA	NA	NA	NA	NA	NA	NA
	116.0"	17.05	NA	NA	NA	NA	NA	NA	NA	NA	NA	NA	NA	NA
	112.0"	18.98	16.44	15.42	NA	NA	NA	NA	NA	NA	NA	NA	NA	NA
	108.0"	21.22	18.38	17.25	16.26	15.39	NA	NA	NA	NA	NA	NA	NA	NA
	104.0"	23.82	20.65	19.38	18.27	17.30	16.43	15.66	NA	NA	NA	NA	NA	NA
	100.0"	26.87	23.30	21.88	20.63	19.53	18.56	17.69	16.91	16.20	15.56	NA	NA	NA
	96.0"	30.45	26.43	24.82	23.41	22.17	21.07	20.09	19.21	18.41	17.69	17.03	16.43	15.87
	92.0"	34.20	30.07	28.31	26.72	25.31	24.06	22.95	21.95	21.04	20.23	19.48	18.79	18.15
	88.0"	36.00	31.69	29.98	28.50	27.20	26.06	25.04	24.14	23.33	22.61	21.95	21.32	20.73
	84.0"	38.00	33.50	31.72	30.18	28.83	27.64	26.58	25.65	24.82	24.05	23.33	22.66	22.02
	80.0"	40.24	35.53	33.67	32.06	30.66	29.42	28.33	27.36	26.48	25.65	24.87	24.14	23.45
	76.0"	42.75	37.82	35.88	34.20	32.73	31.45	30.32	29.29	28.33	27.43	26.58	25.79	25.04
	72.0"	45.60	40.43	38.40	36.64	35.11	33.78	32.57	31.45	30.40	29.42	28.50	27.64	26.82
	68.0"	48.86	43.43	41.30	39.46	37.87	36.44	35.11	33.88	32.73	31.66	30.66	29.71	28.83
	64.0"	52.62	46.90	44.67	42.75	41.04	39.46	38.00	36.64	35.38	34.20	33.10	32.06	31.09
	60.0"	57.00	50.98	48.64	46.57	44.67	42.92	41.30	39.80	38.40	37.10	35.88	34.74	33.67
	56.0"	62.18	55.84	53.30	50.98	48.86	46.90	45.10	43.43	41.88	40.43	39.09	37.82	36.64
	52.0"	68.40	61.60	58.73	56.12	53.73	51.54	49.52	47.65	45.92	44.31	42.81	41.40	40.09
	48.0"	76.00	68.40	65.14	62.18	59.48	57.00	54.72	52.62	50.67	48.86	47.17	45.60	44.13
	44.0"	85.28	76.53	72.80	69.41	66.33	63.50	60.91	58.52	56.32	54.27	52.36	50.59	48.93
	40.0"	96.56	86.40	82.08	78.17	74.62	71.37	68.40	65.66	63.14	60.80	58.63	56.61	54.72
	36.0"	110.55	98.59	93.54	88.98	84.84	81.07	77.62	74.45	71.53	68.83	66.33	64.00	61.83
	32.0"	128.25	114.00	108.00	102.60	97.71	93.27	89.22	85.50	82.08	78.92	76.00	73.29	70.76
	28.0"	150.00	134.01	126.76	120.26	114.40	109.08	104.23	99.79	95.72	91.97	88.50	85.28	82.29
	24.0"	150.00	150.00	150.00	144.00	136.80	130.29	124.36	118.96	114.00	109.44	105.23	101.33	97.71
	20.0"	150.00	150.00	150.00	150.00	150.00	150.00	150.00	145.92	139.71	134.01	128.75	123.89	119.39

INSTRUCTIONS FOR USE OF THE MULLION LOAD TABLE:

1. DETERMINE THE DESIGN LOAD REQUIREMENT PER CHAPTER 16 OF THE FBC FOR THE PARTICULAR OPENING.
2. FOR THE PARTICULAR OPENING, DETERMINE THE TRIBUTARY WIDTH AND MULLION SPAN. REFERENCE THE SKETCHES ON THIS SHEET FOR MULLION SPAN AND TRIBUTARY WIDTH DETERMINATION.
3. IN THE FIRST COLUMN OF THE TABLE, LOCATE THE MULLION SPAN. IN THE FIRST ROW OF THE TABLE, LOCATE THE TRIBUTARY WIDTH. AT THE INTERSECTION OF THE ROW CONTAINING THE MULLION SPAN AND THE COLUMN CONTAINING THE TRIBUTARY WIDTH, READ THE MULLION LOAD RATING GIVEN IN PSF. THE MULLION LOAD RATING MUST BE EQUAL TO OR GREATER THAN THE DESIGN LOAD REQUIREMENT DETERMINED IN STEP 1 ABOVE.

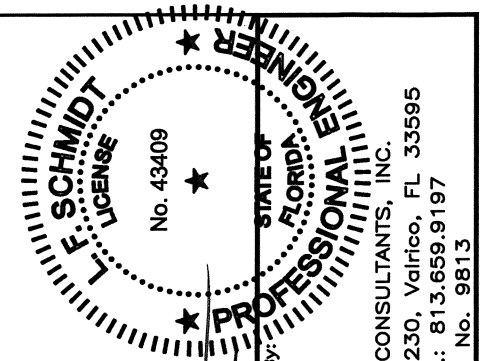

Documents Prepared By:
Lyndon F. Schmidt
P.E. No. 43409

PROFESSIONAL ENGINEER
BUILDING CONSULTANTS, INC.
P.O. Box 230, Valrico, FL 33595
Phone No.: 813.659.9197
FBPE C.A. No. 9813

PRODUCT:	STRUCTURAL MULLION
PART OR ASSEMBLY:	MULLION LOAD TABLE: ANCHOR PLATE (WOOD/CONCRETE SCREWS)
DATE:	02/28/12
SCALE:	NTS
DWG. BY:	EW
CHK. BY:	LFS
DRAWING NO.:	FL-15267.5
SHEET	6 of 9

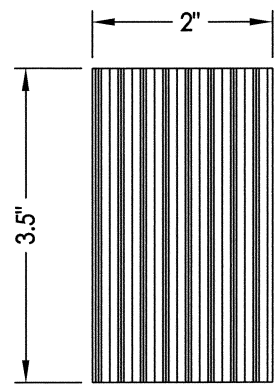

2.5" x 3.5" LVL MULLION

Pacific Wood Laminates Douglas-Fir LVL (PacWorks Series)
Minimum Design Properties: F = 2400 psi, E = 1.8 x 10⁶ psi

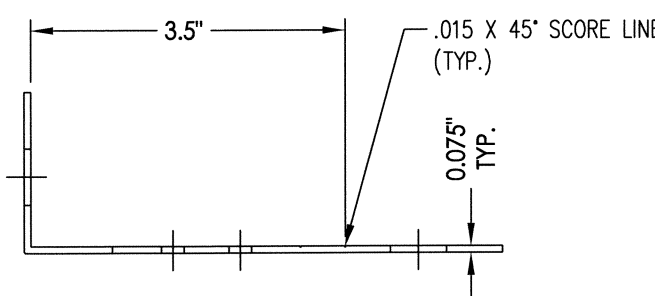
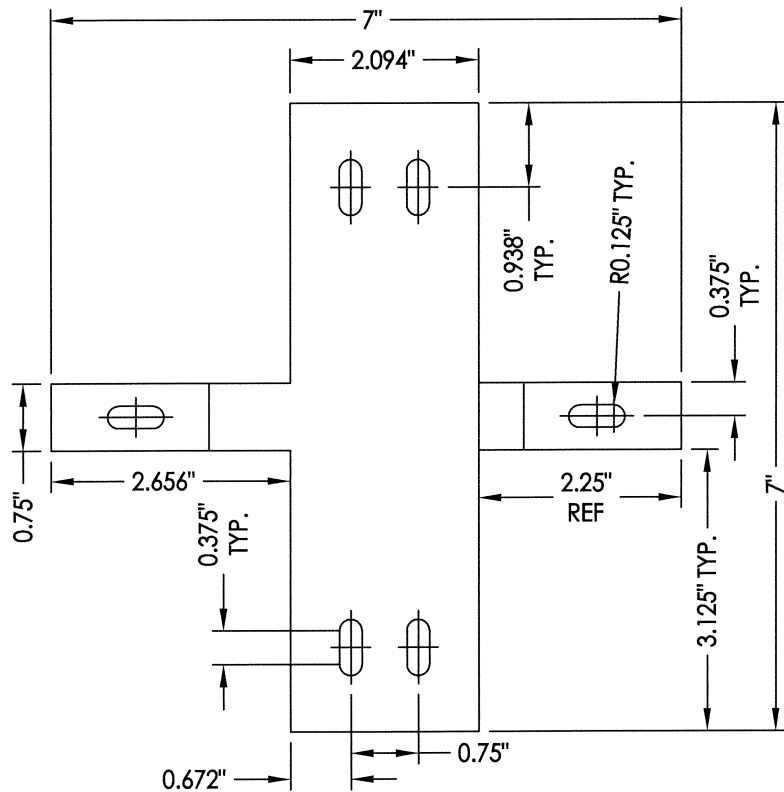

MULLION CLIP - B4
ALUMINUM (6063-T6)

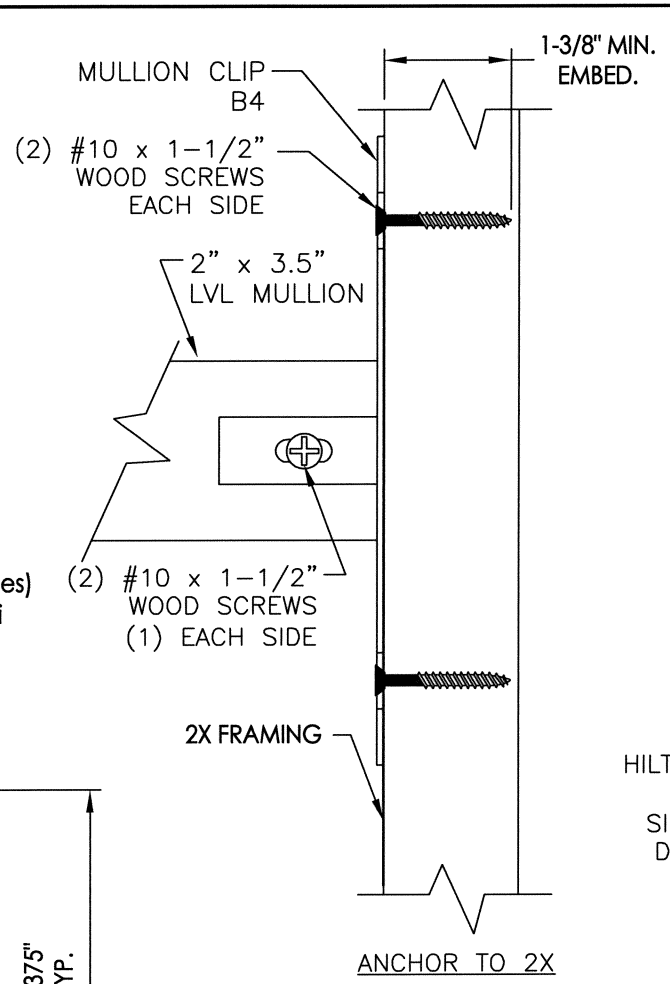

ANCHOR TO 2X

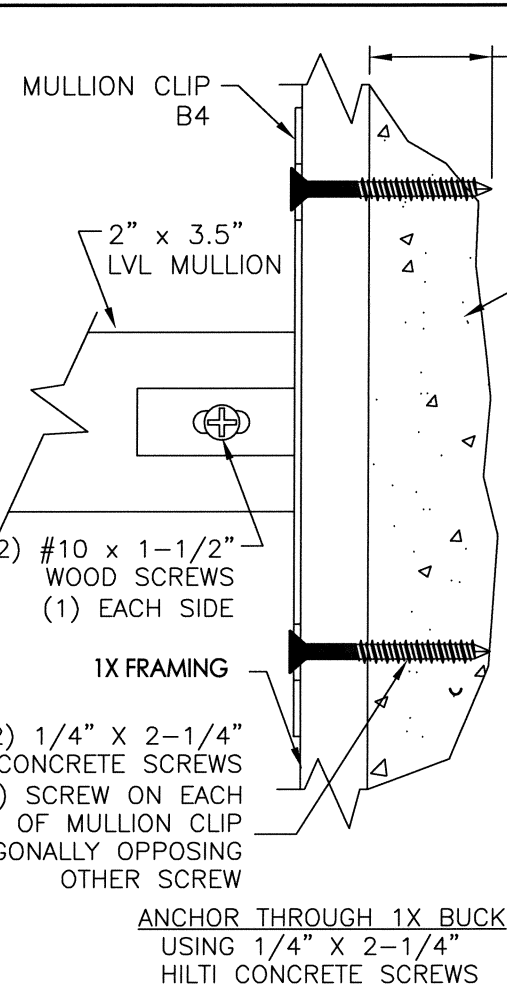

ANCHOR THROUGH 1X BUCK
USING 1/4" X 2-1/4"
HILTI CONCRETE SCREWS

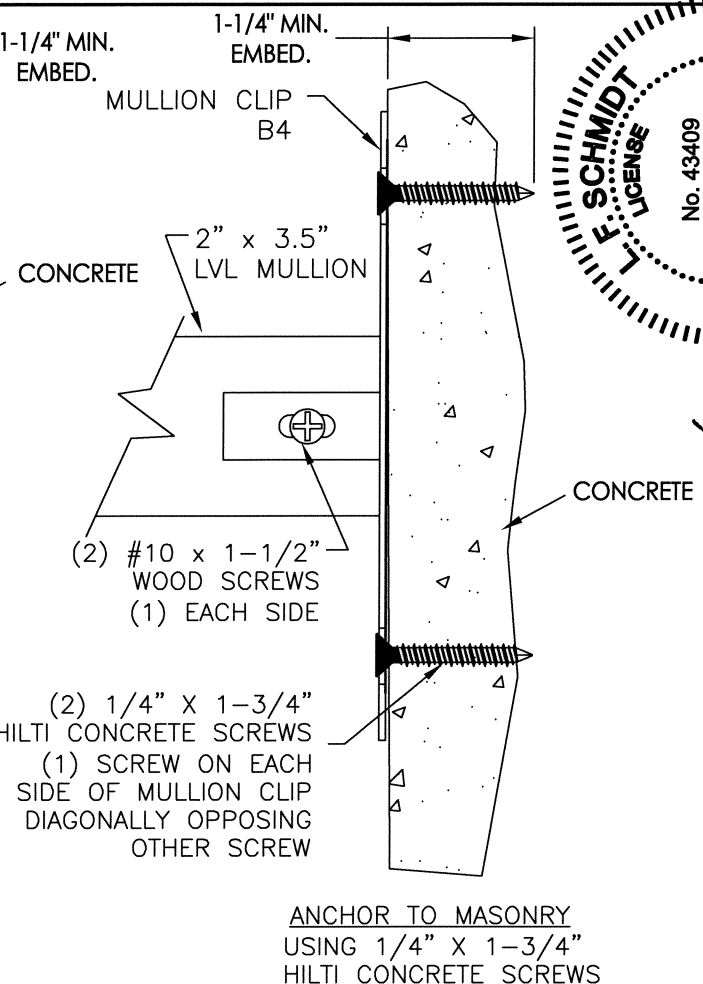

ANCHOR TO MASONRY
USING 1/4" X 1-3/4"
HILTI CONCRETE SCREWS

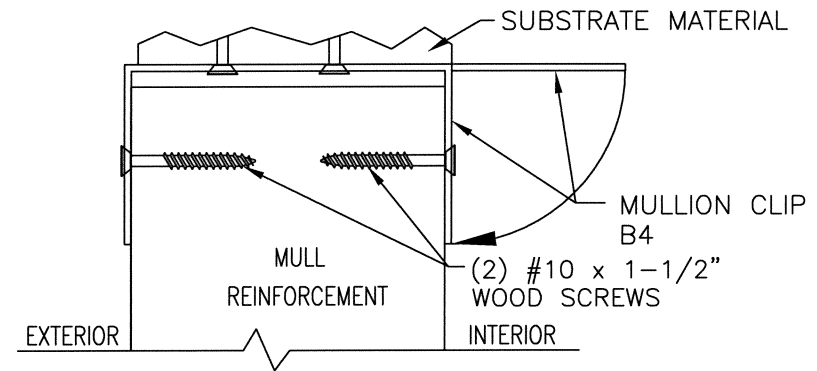

MULLION ANCHOR BRACKET ANCHOR SCHEDULE				
ANCHOR	SUBSTRATE	EMBEDMENT (MIN.)	EDGE DISTANCE (MIN.)	CENTER-TO-CENTER SPACING (MIN.)
#10 PFH WOOD SCREW	WOOD	1-3/8"	1"	1"
1/4" Ø PFH HILTI KWIK-CON II+	HOLLOW BLOCK	1-1/4"	2-1/2"	3"
	CONCRETE	1-1/4"	2-1/2"	3"

CONCRETE CONFORMING TO ACI 301 (3,000 PSI MIN.) OR HOLLOW BLOCK CONFORMING TO ASTM C90
WOOD FRAMING (S.G. >= 0.42)

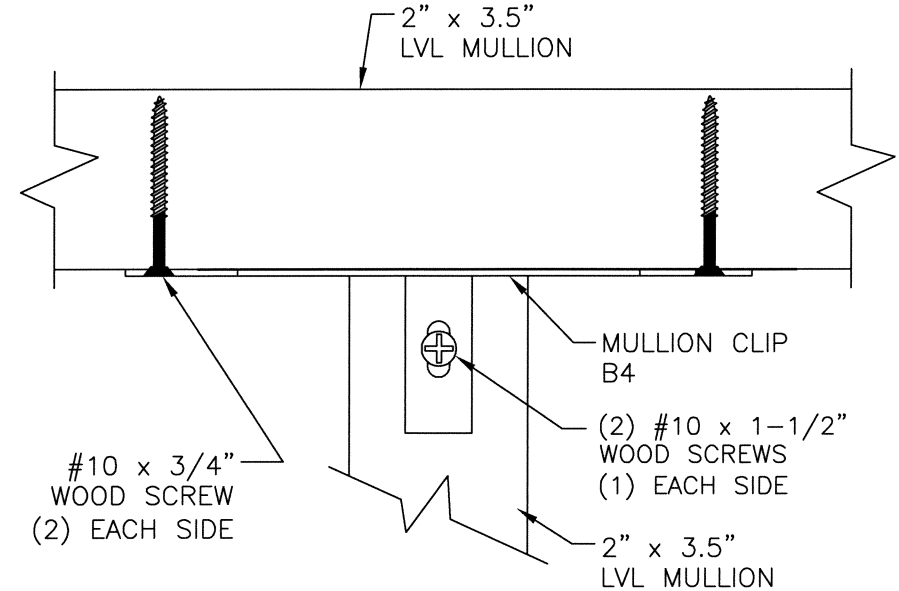

MULLION TO MULLION ANCHORING

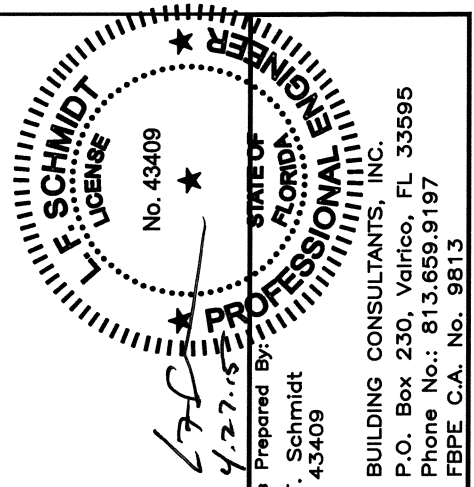

Documents Prepared By: Lyndon F. Schmidt
P.E. No. 43409
R.W. BUILDING CONSULTANTS, INC.
P.O. Box 230, Valrico, FL 33595
Phone No.: 813.659.9197
FBPE C.A. No. 9813

PRODUCT:	STRUCTURAL MULLION	
PART OR ASSEMBLY:	ANCHORING CLIP B4 ANCHORING DETAILS	
DATE	NO.	BY
4/17/15	1	LFS
UPDATE TO 5TH ED. (2014) FBC		
REVISIONS		
DATE:	02/28/12	
SCALE:	NTS	
DWG. BY:	EW	
CHK. BY:	LFS	
DRAWING NO.:	FL-15267.5	
SHEET	7 OF 9	

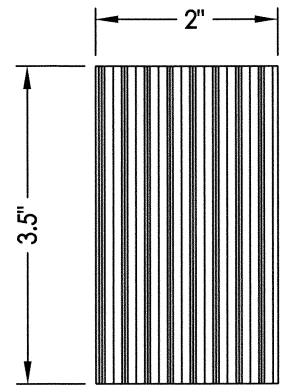

2.5" x 3.5" LVL MULLION

Pacific Wood Laminates Douglas-Fir LVL (PacWorks Series)
Minimum Design Properties: F = 2400 psi, E = 1.8 x 10 psi

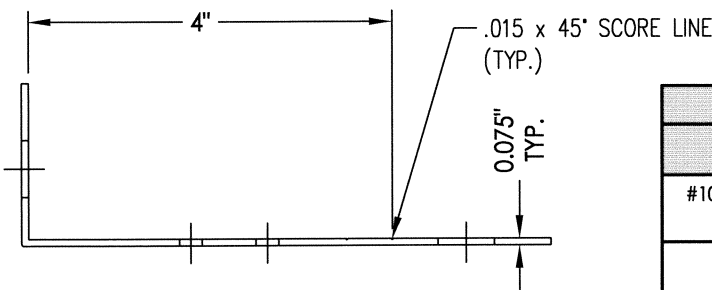
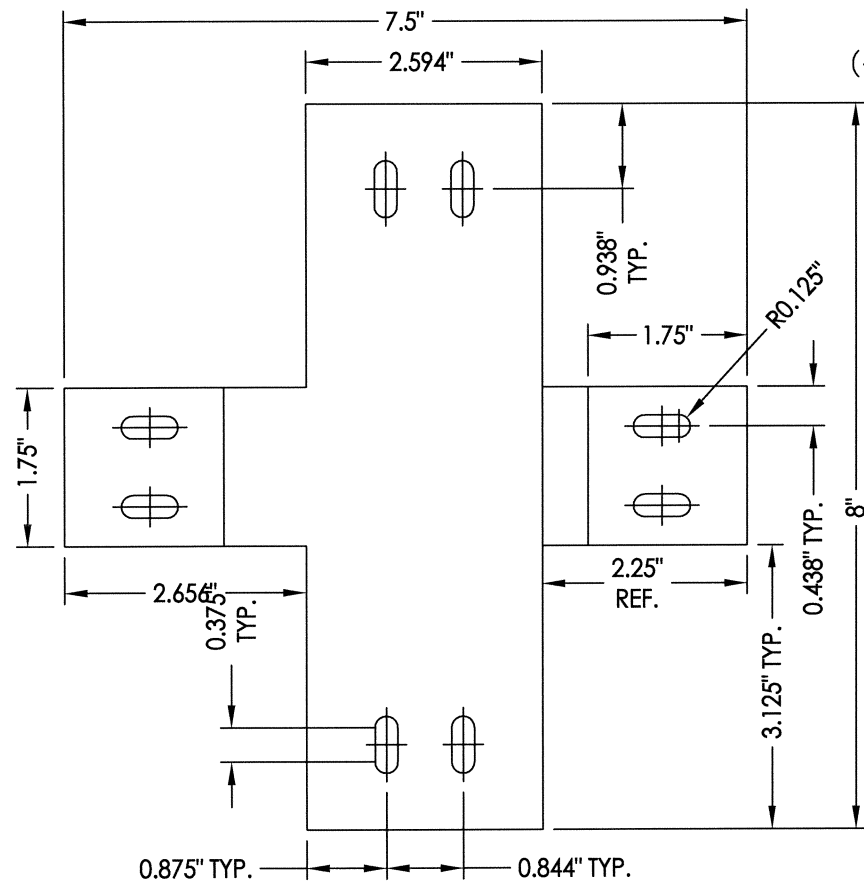

MULL CLIP - B1
ALUMINUM (6063-T6)

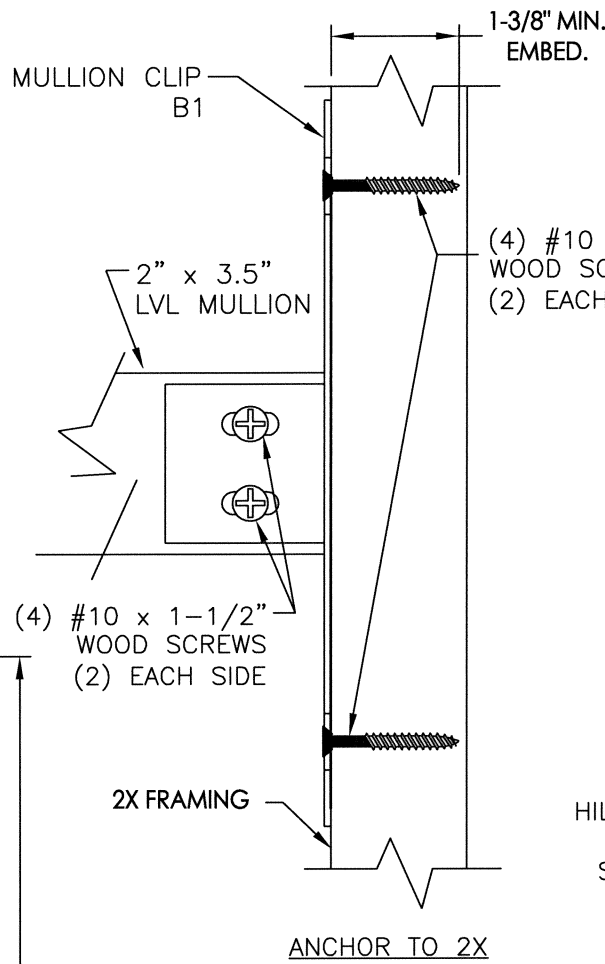

ANCHOR TO 2X

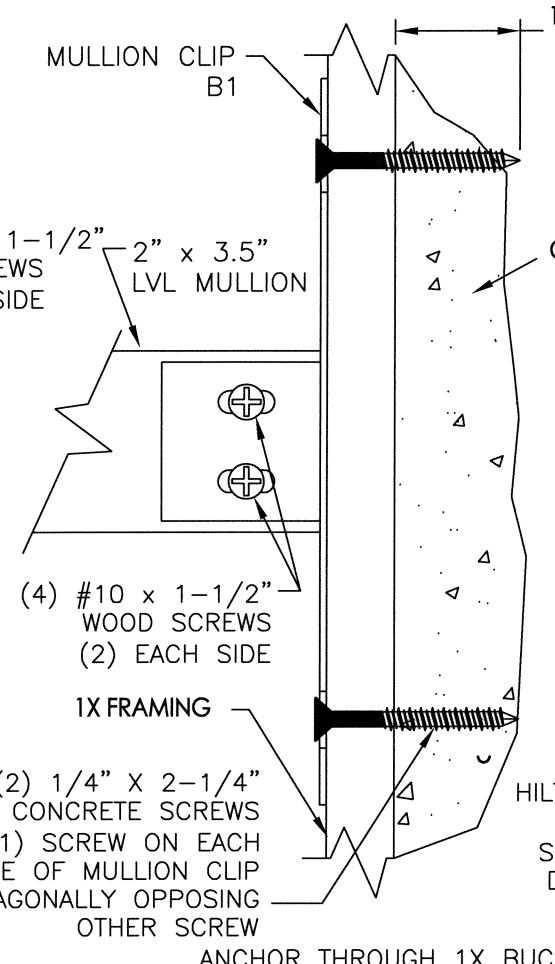

ANCHOR THROUGH 1X BUCK
USING 1/4\"/>

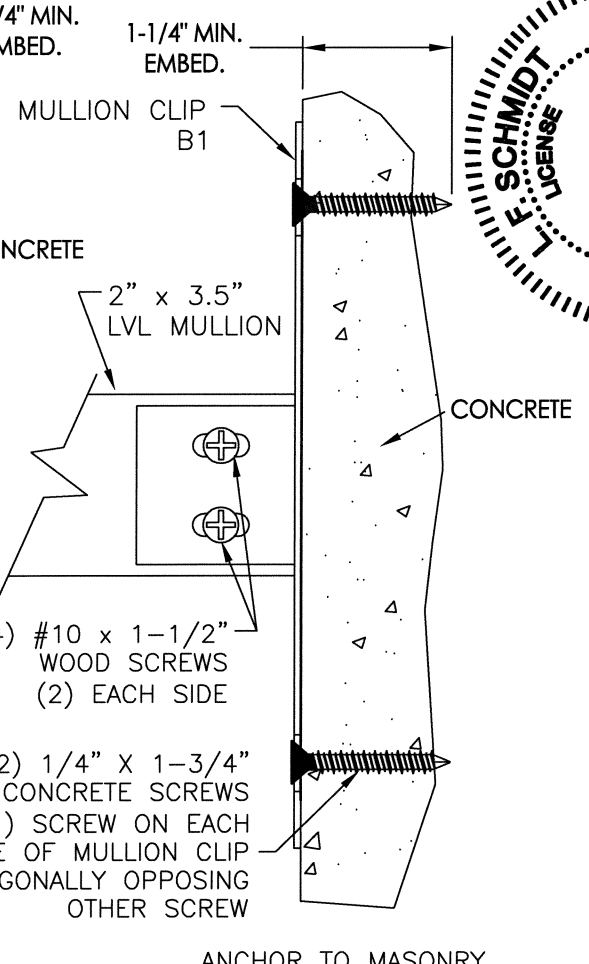

ANCHOR TO MASONRY
USING 1/4\"/>

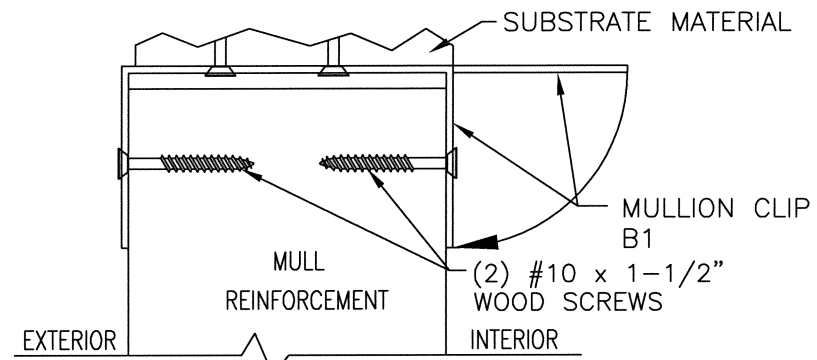

INSTALLATION PROCEDURE
SEE 2X, 1X TO MASONRY & MASONRY ANCHORING ABOVE

MULLION ANCHOR BRACKET ANCHOR SCHEDULE				
ANCHOR	SUBSTRATE	EMBEDMENT (MIN.)	EDGE DISTANCE (MIN.)	CENTER-TO-CENTER SPACING (MIN.)
#10 PFH WOOD SCREW	WOOD	1-3/8"	1"	1"
1/4" Ø PFH HILTI KWIK-CON II+	HOLLOW BLOCK	1-1/4"	2-1/2"	3"
	CONCRETE	1-1/4"	2-1/2"	3"

CONCRETE CONFORMING TO ACI 301 (3,000 PSI MIN.) OR HOLLOW BLOCK CONFORMING TO ASTM C90 WOOD FRAMING (S.G. >= 0.42)

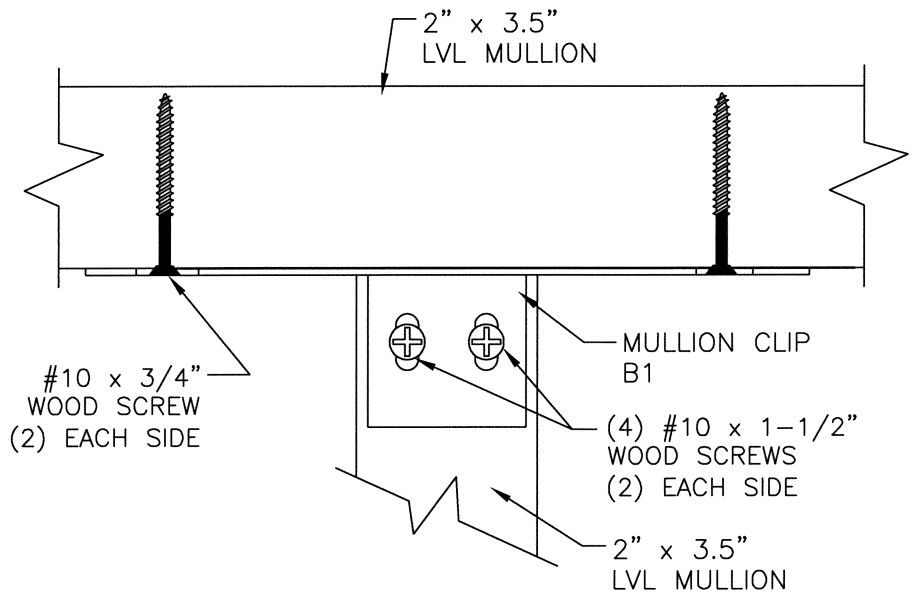

MULLION TO MULLION ANCHORING

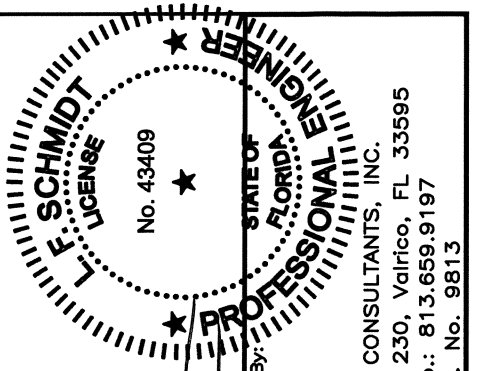

Documents Prepared By:
Lyndon F. Schmidt
P.E. No. 43409

RW BUILDING CONSULTANTS, INC.
P.O. Box 230, Vairico, FL 33595
Phone No.: 813.659.9197
FBPE C.A. No. 9813

PRODUCT:	STRUCTURAL MULLION
PART OR ASSEMBLY:	ANCHORING CLIP B1 ANCHORING DETAILS
NO.	1
DATE	4/17/15
REVISIONS	UPDATE TO 5TH ED. (2014) FBC
DATE	02/28/12
SCALE:	NTS
DWG. BY:	EW
CHK. BY:	LFS
DRAWING NO.:	FL-15267.5
SHEET	8 OF 9

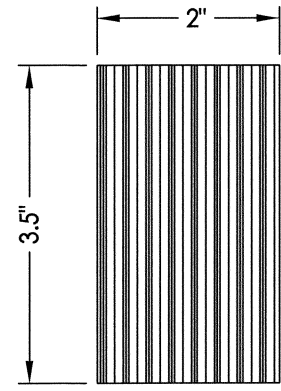

2.5" x 3.5" LVL MULLION

Pacific Wood Laminates Douglas-Fir LVL (PacWorks Series)
Minimum Design Properties: F = 2400 psi, E = 1.8 x 10⁶ psi

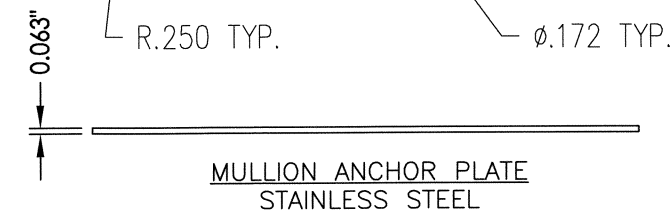
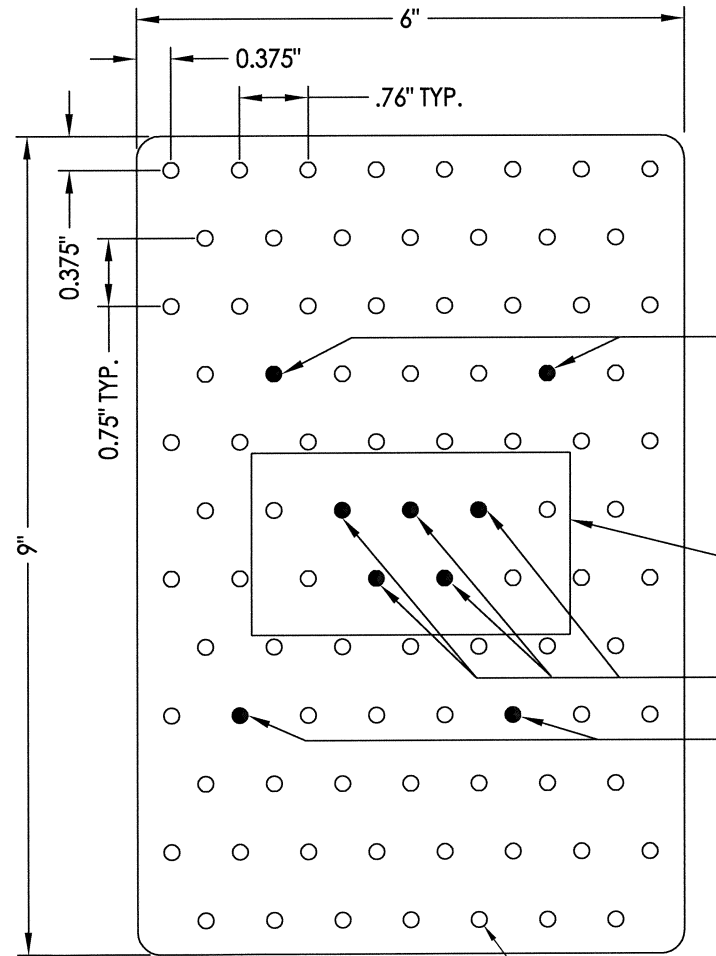

**MULLION ANCHOR PLATE
STAINLESS STEEL**

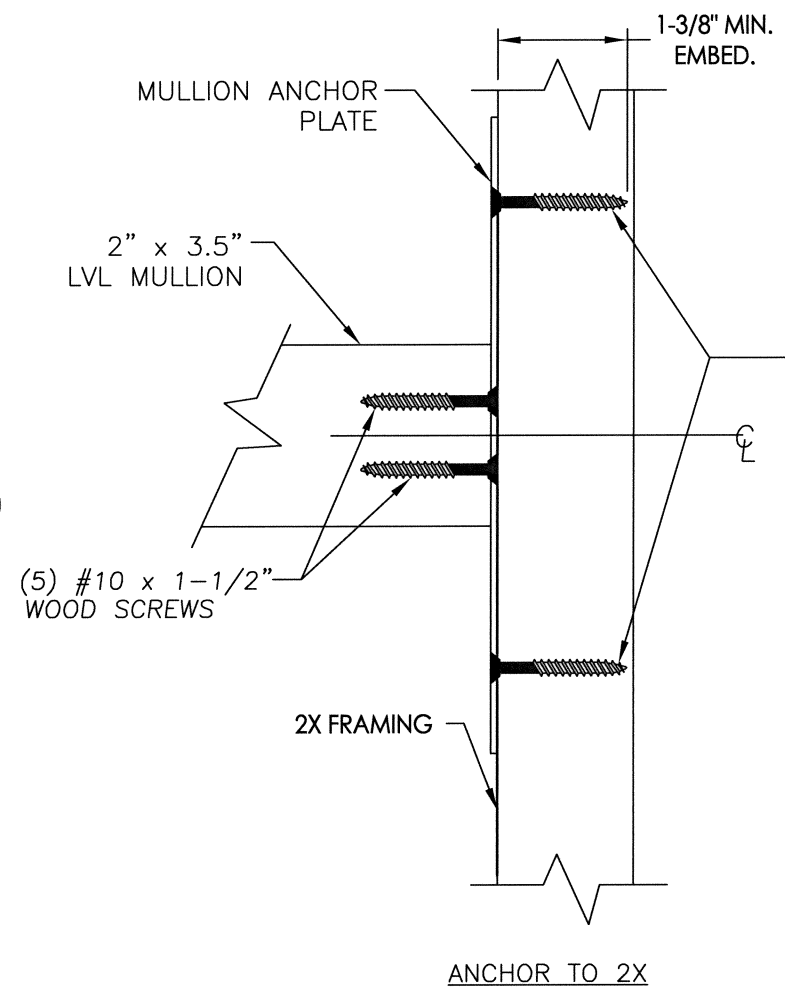

ANCHOR TO 2X

ANCHOR PLATE TO SUBSTRATE ANCHOR SCREW LOCATIONS. (WOOD OR CONCRETE SUBSTRATE)

2" x 3.5" LVL MULLION LOCATION

ANCHOR PLATE TO MULLION ANCHOR SCREWS
(5) #10 X 1-1/2" WOOD SCREWS

MULLION ANCHOR BRACKET ANCHOR SCHEDULE				
ANCHOR	SUBSTRATE	EMBEDMENT (MIN.)	EDGE DISTANCE (MIN.)	CENTER-TO-CENTER SPACING (MIN.)
#10 PFH WOOD SCREW	WOOD	1-3/8"	1"	1"
1/4" Ø PFH HILTI KWIK-CON II+	HOLLOW BLOCK	1-1/4"	2-1/2"	3"
	CONCRETE	1-1/4"	2-1/2"	3"

CONCRETE CONFORMING TO ACI 301 (3,000 PSI MIN.) OR HOLLOW BLOCK CONFORMING TO ASTM C90 WOOD FRAMING (S.G. >= 0.42)

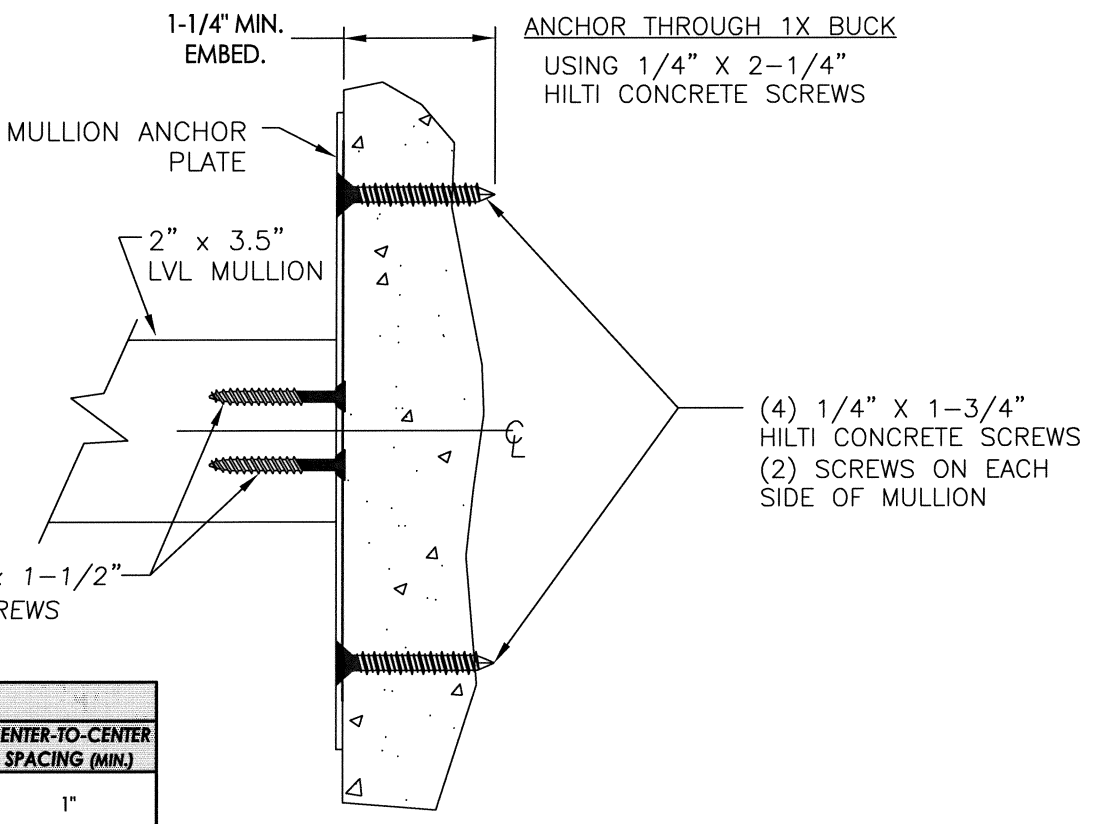

**ANCHOR TO MASONRY
USING 1/4" X 1-3/4" HILTI CONCRETE SCREWS**

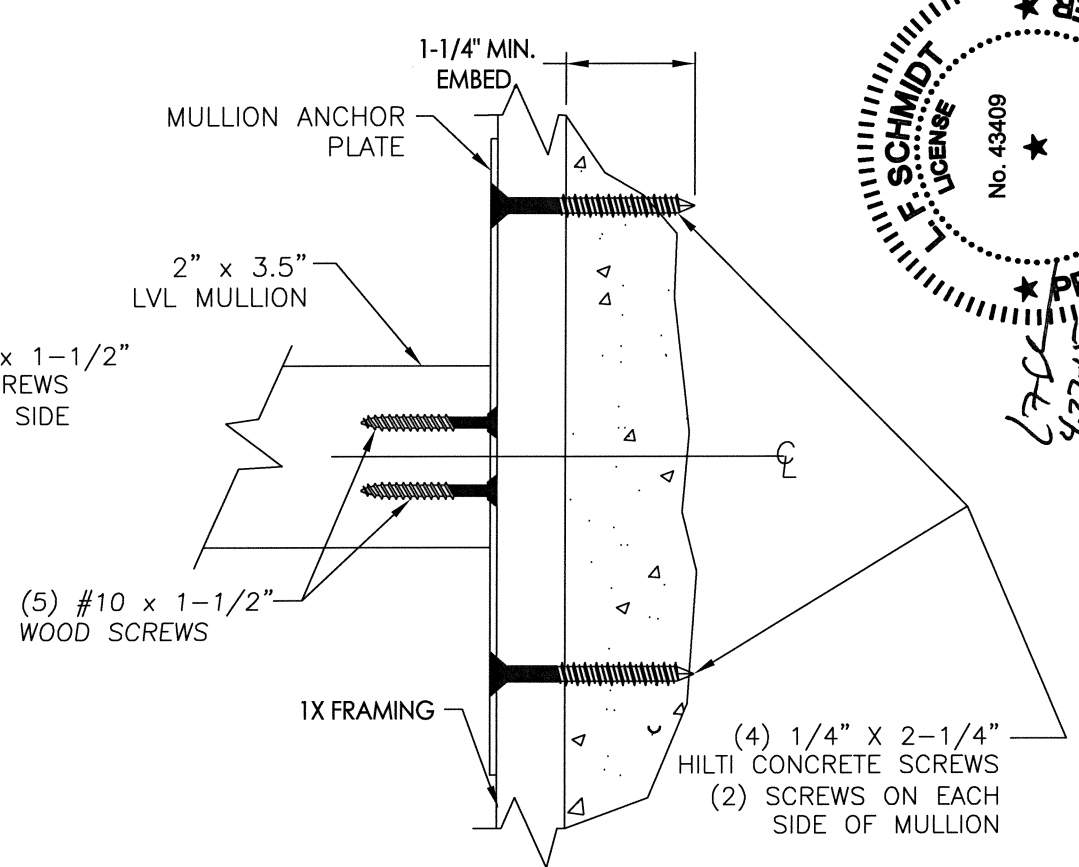

**(4) 1/4" X 2-1/4" HILTI CONCRETE SCREWS
(2) SCREWS ON EACH SIDE OF MULLION**

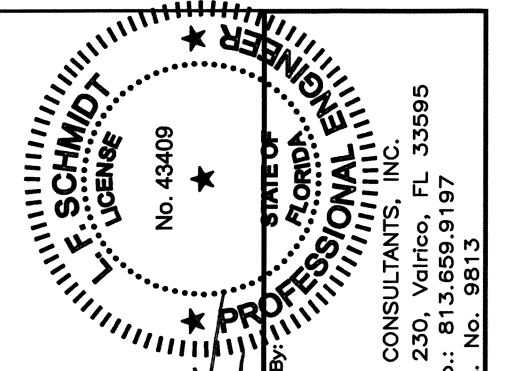

Documents Prepared By:
Lyndon F. Schmidt
P.E. No. 43409

RW BUILDING CONSULTANTS, INC.
P.O. Box 230, Vairico, FL 33595
Phone No.: 813.659.9197
FBPE C.A. No. 9813

PRODUCT:	STRUCTURAL MULLION
PART OR ASSEMBLY:	MULLION ANCHOR PLATE: ANCHORING DETAILS
NO.	1
DATE	4/17/15
UPDATE TO	5TH ED. (2014) FBC
LFS BY	
REVISIONS	
DATE:	02/28/12
SCALE:	NTS
DWG. BY:	EW
CHK. BY:	LFS
DRAWING NO.:	FL-15267.5
SHEET	9 OF 9