

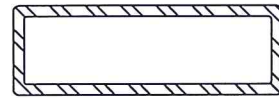

E-Series/Eagle

2045 Kerper Blvd., Dubuque, IA 52004-1072

STRUCTURAL STEEL MULLION



1" x 3" x 1/8" STEEL MULLION

GENERAL NOTES:

1. This product has been evaluated and is in compliance with the 5th Edition (2014) Florida Building Code (FBC) structural requirements excluding the "High Velocity Hurricane Zone".
2. When used in areas requiring wind borne debris protection this product complies with Section 1609.1.2 of the FBC and does not require an impact resistant covering. This product meets missile level "D" and excludes Wind Zone 4 as defined in ASTM E 1996 and Section 1609.1.2.2 of the FBC.
3. Wood bucks by others, must be anchored properly to transfer loads to the structure and be reviewed by the Building Official.
4. Mullion anchor embedment to base material shall be beyond wall dressing or stucco.
5. Separate product approvals for each glazing product used with these mullions must be submitted along with this mullion product approval.
6. Anchoring of each glazing product to the mullion shall be as shown in each individual glazing product approval.
7. Any conditions not covered in this evaluation are subject to separate Engineering evaluation.
8. Mullion design pressure rating, see load rating table sheets 2 - 5 of this drawing.
9. The design pressure rating of the assembly shall be the lesser of the load capacity of the mullion as determined using this approval or the design pressure rating of the individual glazing products used.

TABLE OF CONTENTS	
SHEET #	DESCRIPTION
1	Typical Elevations & General Notes
2	Mullion Load Table: Anchor Clip F2 (Concrete Screws)
3	Mullion Load Table: Anchor Clip F2 (Wood Screws)
4	Mullion Load Table: Anchor Clip B4 (Concrete Screws)
5	Mullion Load Table: Anchor Clip B4 (Wood Screws)
6	Anchor Clip F2: Anchoring Details
7	Anchor Clip B4: Anchoring Details

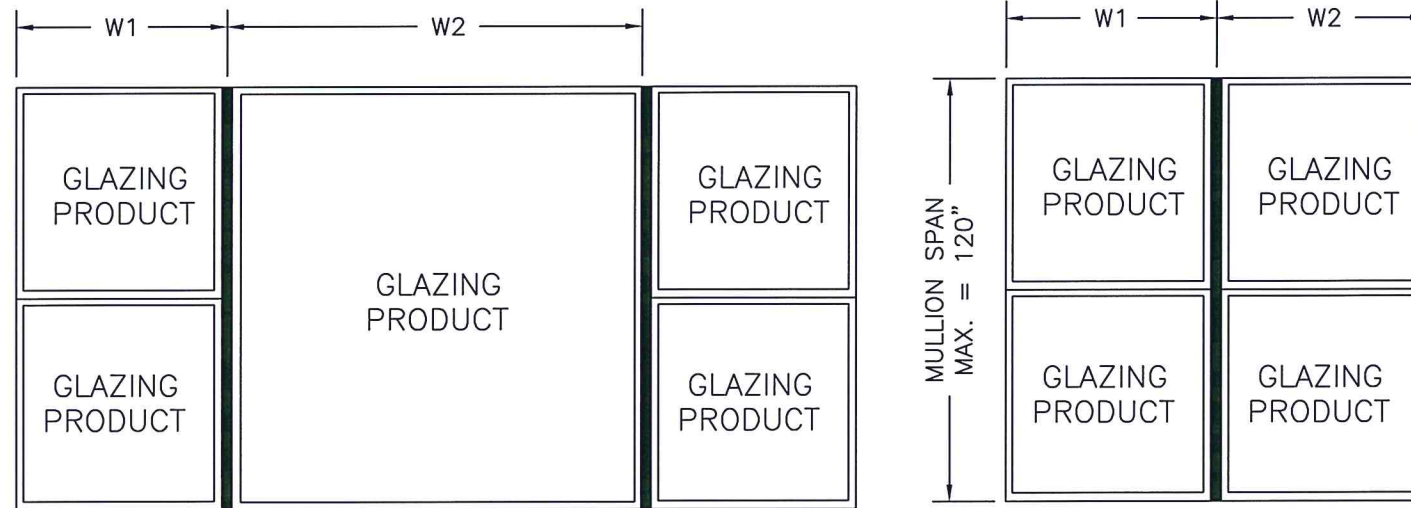
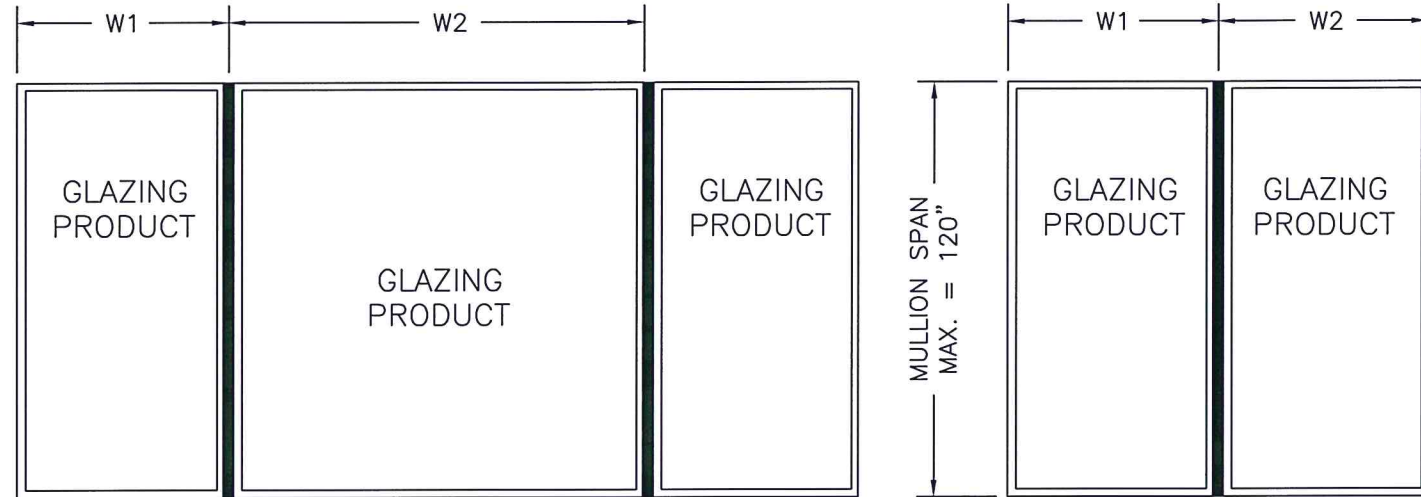

TYPICAL MULLION CONFIGURATIONS

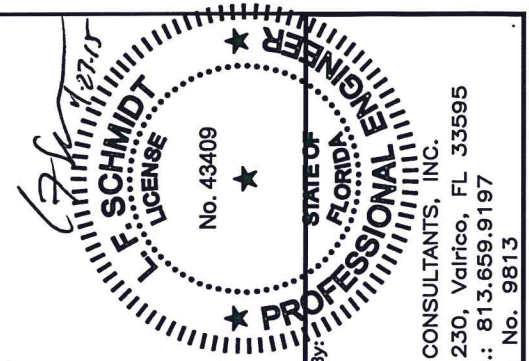

Documents Prepared By:
Lyndon F. Schmidt
P.E. No. 43409

RW BUILDING CONSULTANTS, INC.
P.O. Box 230, Valrico, FL 33595
Phone No.: 813.659.9197
FBPE C.A. No. 9813

PRODUCT: STRUCTURAL MULLION

PART OR ASSEMBLY: TYPICAL ELEVATION & GENERAL NOTES

NO.	DATE	REVISIONS	BY
1	4/17/15	UPDATE TO 5TH ED. (2014) FBC	LFS

DATE: 02/28/12

SCALE: NTS

DWG. BY: EW

CHK. BY: LFS

DRAWING NO.: FL-15267.3

SHEET 1 OF 7

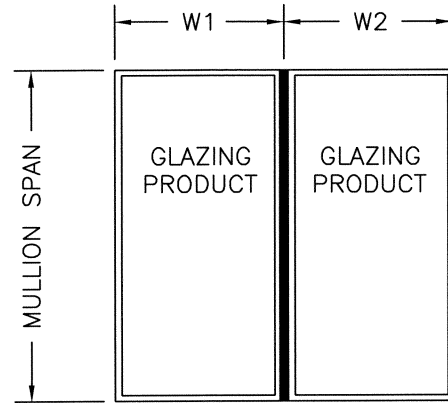

$$\text{TRIBUTARY WIDTH} = \frac{W1 + W2}{2}$$

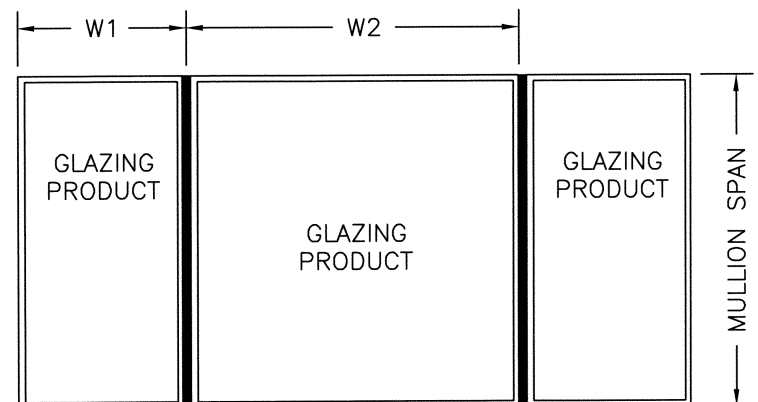

1" x 3" x .125" STEEL STRUCTURAL BEAM MULLION LOAD TABLE (PSF) - ANCHOR CLIP F2

CONCRETE SCREW	TRIBUTARY WIDTH													
	24.0"	28.0"	30.0"	32.0"	34.0"	36.0"	38.0"	40.0"	42.0"	44.0"	46.0"	48.0"	50.0"	
120.0"	40.13	34.73	32.46	30.43	28.64	27.05	25.63	24.35	23.19	22.13	21.17	20.29	19.48	
116.0"	43.42	37.22	34.74	32.57	30.65	28.95	27.43	26.05	24.81	23.69	22.66	21.71	20.84	
112.0"	46.58	39.93	37.27	34.94	32.88	31.05	29.42	27.95	26.62	25.41	24.30	23.29	22.36	
108.0"	50.10	42.94	40.08	37.57	35.36	33.40	31.64	30.06	28.63	27.33	26.14	25.05	24.05	
104.0"	54.02	46.31	43.22	40.52	38.13	36.02	34.12	32.41	30.87	29.47	28.19	27.01	25.93	
100.0"	58.43	50.08	46.75	43.82	41.25	38.95	36.90	35.06	33.39	31.87	30.49	29.22	28.05	
96.0"	63.40	54.35	50.72	47.55	44.75	42.27	40.04	38.04	36.23	34.58	33.08	31.70	30.43	
92.0"	69.04	59.17	55.23	51.78	48.73	46.02	43.60	41.42	39.45	37.66	36.02	34.52	33.14	
88.0"	75.45	64.68	60.36	56.59	53.26	50.30	47.66	45.27	43.12	41.16	39.37	37.73	36.22	
84.0"	82.81	70.98	66.25	62.11	58.46	55.21	52.30	49.69	47.32	45.17	43.21	41.41	39.75	
80.0"	88.59	78.23	73.04	68.48	64.45	60.87	57.66	54.78	52.17	49.80	47.63	45.65	43.82	
76.0"	94.13	83.28	79.00	75.30	71.41	67.44	63.89	60.70	57.81	55.18	52.78	50.58	48.56	
72.0"	100.40	89.02	84.55	80.68	77.31	74.37	71.19	67.63	64.41	61.48	58.81	56.36	54.10	
68.0"	107.57	95.62	90.93	86.88	83.38	80.23	77.31	74.60	72.07	68.93	65.93	63.18	60.66	
64.0"	115.85	103.27	98.35	94.13	90.36	86.88	83.67	80.68	77.90	75.30	72.87	70.59	68.45	
60.0"	125.50	112.25	107.09	102.54	98.35	94.49	90.93	87.62	84.55	81.68	79.00	76.50	74.14	
56.0"	136.91	122.94	117.35	112.25	107.57	103.27	99.30	95.62	92.20	89.02	86.06	83.28	80.68	
52.0"	150.00	135.62	129.32	123.57	118.31	113.48	109.03	104.92	101.10	97.55	94.25	91.16	88.26	
48.0"	150.00	150.00	143.43	136.91	130.96	125.50	120.48	115.85	111.56	107.57	103.86	100.40	97.16	
44.0"	150.00	150.00	150.00	150.00	146.04	139.82	134.12	128.86	123.99	119.48	115.29	111.38	107.73	
40.0"	150.00	150.00	150.00	150.00	150.00	150.00	150.00	144.58	139.02	133.87	129.09	124.63	120.48	
36.0"	150.00	150.00	150.00	150.00	150.00	150.00	150.00	150.00	150.00	150.00	146.04	140.91	136.14	
32.0"	150.00	150.00	150.00	150.00	150.00	150.00	150.00	150.00	150.00	150.00	150.00	150.00	150.00	
28.0"	150.00	150.00	150.00	150.00	150.00	150.00	150.00	150.00	150.00	150.00	150.00	150.00	150.00	
24.0"	150.00	150.00	150.00	150.00	150.00	150.00	150.00	150.00	150.00	150.00	150.00	150.00	150.00	
20.0"	150.00	150.00	150.00	150.00	150.00	150.00	150.00	150.00	150.00	150.00	150.00	150.00	150.00	

INSTRUCTIONS FOR USE OF THE MULLION LOAD TABLE:

1. DETERMINE THE DESIGN LOAD REQUIREMENT PER CHAPTER 16 OF THE FBC FOR THE PARTICULAR OPENING.
2. FOR THE PARTICULAR OPENING, DETERMINE THE TRIBUTARY WIDTH AND MULLION SPAN. REFERENCE THE SKETCHES ON THIS SHEET FOR MULLION SPAN AND TRIBUTARY WIDTH DETERMINATION.
3. IN THE FIRST COLUMN OF THE TABLE, LOCATE THE MULLION SPAN. IN THE FIRST ROW OF THE TABLE, LOCATE THE TRIBUTARY WIDTH. AT THE INTERSECTION OF THE ROW CONTAINING THE MULLION SPAN AND THE COLUMN CONTAINING THE TRIBUTARY WIDTH, READ THE MULLION LOAD RATING GIVEN IN PSF. THE MULLION LOAD RATING MUST BE EQUAL TO OR GREATER THAN THE DESIGN LOAD REQUIREMENT DETERMINED IN STEP 1 ABOVE.

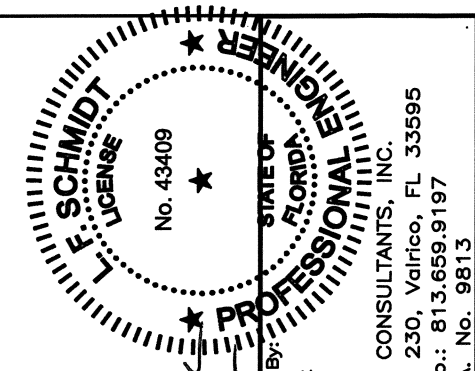

Documents Prepared By:
 Lyndon F. Schmidt
 P.E. No. 43409

BUILDING CONSULTANTS, INC.
 P.O. Box 230, Valrico, FL 33595
 Phone No.: 813.659.9197
 FBPE C.A. No. 9813

PRODUCT:	STRUCTURAL MULLION
PART OR ASSEMBLY:	MULLION LOAD TABLE: ANCHOR CLIP F2 (CONCRETE SCREWS)
DATE:	02/28/12
SCALE:	NTS
DWG. BY:	EW
CHK. BY:	LFS
DRAWING NO.:	FL-15267.3
SHEET	2 OF 7

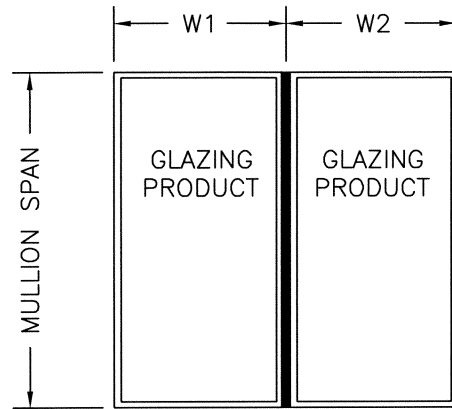

$$\text{TRIBUTARY WIDTH} = \frac{W1 + W2}{2}$$

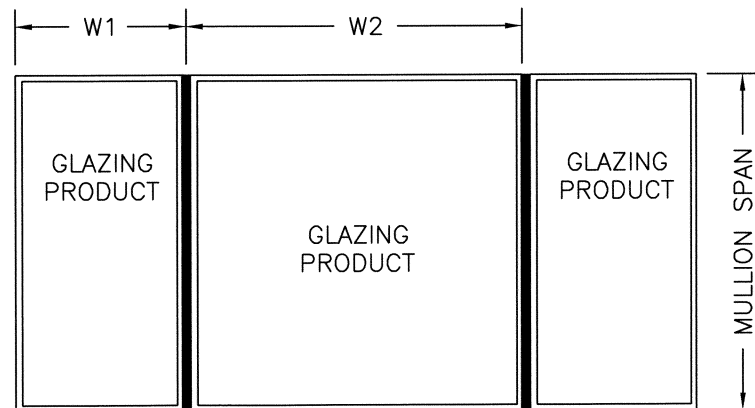

1" x 3" x .125" STEEL STRUCTURAL BEAM MULLION LOAD TABLE (PSF) - ANCHOR CLIP F2

WOOD SCREW	TRIBUTARY WIDTH													
	24.0"	28.0"	30.0"	32.0"	34.0"	36.0"	38.0"	40.0"	42.0"	44.0"	46.0"	48.0"	50.0"	
120.0"	40.13	34.73	32.46	30.43	28.64	27.05	25.63	24.35	23.19	22.13	21.17	20.29	19.48	
116.0"	43.42	37.22	34.74	32.57	30.65	28.95	27.43	26.05	24.81	23.69	22.66	21.71	20.84	
112.0"	46.58	39.93	37.27	34.94	32.88	31.05	29.42	27.95	26.62	25.41	24.30	23.29	22.36	
108.0"	50.10	42.94	40.08	37.57	35.36	33.40	31.64	30.06	28.63	27.33	26.14	25.05	24.05	
104.0"	54.02	46.31	43.22	40.52	38.13	36.02	34.12	32.41	30.87	29.47	28.19	27.01	25.93	
100.0"	58.43	50.08	46.75	43.82	41.25	38.95	36.90	35.06	33.39	31.87	30.49	29.22	28.05	
96.0"	63.40	54.35	50.72	47.55	44.75	42.27	40.04	38.04	36.23	34.58	33.08	31.70	30.43	
92.0"	69.04	59.17	55.23	51.78	48.73	46.02	43.60	41.42	39.45	37.66	36.02	34.52	33.14	
88.0"	75.45	64.68	60.36	56.59	53.26	50.30	47.66	45.27	43.12	41.16	39.37	37.73	36.22	
84.0"	82.81	70.98	66.25	62.11	58.46	55.21	52.30	49.69	47.32	45.17	43.21	41.41	39.75	
80.0"	91.30	78.26	73.04	68.48	64.45	60.87	57.66	54.78	52.17	49.80	47.63	45.65	43.82	
76.0"	101.16	86.71	80.93	75.87	71.41	67.44	63.89	60.70	57.81	55.18	52.78	50.58	48.56	
72.0"	112.72	96.61	90.17	84.54	79.56	75.14	71.19	67.63	64.41	61.48	58.81	56.36	54.10	
68.0"	126.37	108.31	101.09	94.78	89.20	84.24	79.81	75.82	72.21	68.93	65.93	63.18	60.66	
64.0"	142.66	122.28	114.13	106.99	100.70	95.10	90.10	85.59	81.52	77.81	74.43	71.33	68.48	
60.0"	150.00	139.12	129.85	121.73	114.57	108.21	102.51	97.39	92.75	88.53	84.68	81.16	77.91	
56.0"	150.00	150.00	149.06	139.74	131.52	124.22	117.68	111.80	106.47	101.63	97.21	93.16	89.44	
52.0"	150.00	150.00	150.00	150.00	150.00	144.06	136.48	129.66	123.48	117.87	112.75	108.05	103.73	
48.0"	150.00	150.00	150.00	150.00	150.00	150.00	150.00	150.00	144.92	138.33	132.32	126.81	121.73	
44.0"	150.00	150.00	150.00	150.00	150.00	150.00	150.00	150.00	150.00	150.00	150.00	150.00	144.87	
40.0"	150.00	150.00	150.00	150.00	150.00	150.00	150.00	150.00	150.00	150.00	150.00	150.00	150.00	
36.0"	150.00	150.00	150.00	150.00	150.00	150.00	150.00	150.00	150.00	150.00	150.00	150.00	150.00	
32.0"	150.00	150.00	150.00	150.00	150.00	150.00	150.00	150.00	150.00	150.00	150.00	150.00	150.00	
28.0"	150.00	150.00	150.00	150.00	150.00	150.00	150.00	150.00	150.00	150.00	150.00	150.00	150.00	
24.0"	150.00	150.00	150.00	150.00	150.00	150.00	150.00	150.00	150.00	150.00	150.00	150.00	150.00	
20.0"	150.00	150.00	150.00	150.00	150.00	150.00	150.00	150.00	150.00	150.00	150.00	150.00	150.00	

INSTRUCTIONS FOR USE OF THE MULLION LOAD TABLE:

1. DETERMINE THE DESIGN LOAD REQUIREMENT PER CHAPTER 16 OF THE FBC FOR THE PARTICULAR OPENING.
2. FOR THE PARTICULAR OPENING, DETERMINE THE TRIBUTARY WIDTH AND MULLION SPAN. REFERENCE THE SKETCHES ON THIS SHEET FOR MULLION SPAN AND TRIBUTARY WIDTH DETERMINATION.
3. IN THE FIRST COLUMN OF THE TABLE, LOCATE THE MULLION SPAN. IN THE FIRST ROW OF THE TABLE, LOCATE THE TRIBUTARY WIDTH. AT THE INTERSECTION OF THE ROW CONTAINING THE MULLION SPAN AND THE COLUMN CONTAINING THE TRIBUTARY WIDTH, READ THE MULLION LOAD RATING GIVEN IN PSF. THE MULLION LOAD RATING MUST BE EQUAL TO OR GREATER THAN THE DESIGN LOAD REQUIREMENT DETERMINED IN STEP 1 ABOVE.

Documents Prepared By: *LFS*
 Lyndon F. Schmidt
 P.E. No. 43409

RW
 BUILDING CONSULTANTS, INC.
 P.O. Box 230, Valrico, FL 33595
 Phone No.: 813.659.9197
 FBPE C.A. No. 9813

PRODUCT:		STRUCTURAL MULLION	
PART OR ASSEMBLY:		MULLION LOAD TABLE: ANCHOR CLIP F2 (WOOD SCREWS)	
DATE:	02/28/12	NO.	1
SCALE:	NTS	DATE	4/17/15
DWG. BY:	EW	BY	LFS
CHK. BY:	LFS	REVISIONS	UPDATE TO 5TH ED. (2014) FBC
DRAWING NO.:	FL-15267.3		
SHEET	3	OF	7

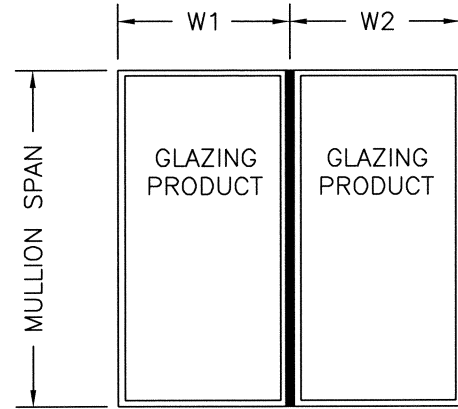

$$\text{TRIBUTARY WIDTH} = \frac{W1 + W2}{2}$$

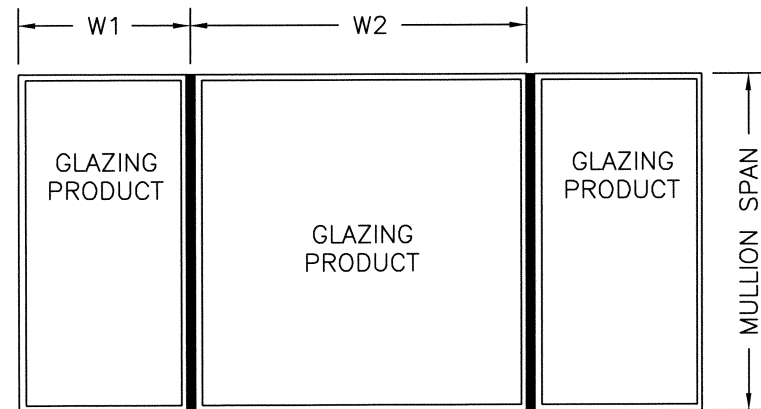

CONCRETE SCREW	1" x 3" x .125" STEEL STRUCTURAL BEAM MULLION LOAD TABLE (PSF) - ANCHOR CLIP B4													
	TRIBUTARY WIDTH													
	24.0"	28.0"	30.0"	32.0"	34.0"	36.0"	38.0"	40.0"	42.0"	44.0"	46.0"	48.0"	50.0"	
120.0"	40.13	34.73	32.46	30.43	28.64	27.05	25.63	24.35	23.19	22.13	21.17	20.29	19.48	
116.0"	43.42	37.22	34.74	32.57	30.65	28.95	27.43	26.05	24.81	23.69	22.66	21.71	20.84	
112.0"	45.24	39.57	37.27	34.94	32.88	31.05	29.42	27.95	26.62	25.41	24.30	23.29	22.36	
108.0"	47.13	41.25	38.92	36.88	35.09	33.40	31.64	30.06	28.63	27.33	26.14	25.05	24.05	
104.0"	49.17	43.09	40.67	38.56	36.71	35.07	33.61	32.31	30.87	29.47	28.19	27.01	25.93	
100.0"	51.41	45.09	42.58	40.39	38.47	36.78	35.27	33.93	32.72	31.64	30.49	29.22	28.05	
96.0"	53.86	47.29	44.68	42.41	40.42	38.67	37.11	35.72	34.47	33.35	32.33	31.42	30.43	
92.0"	56.55	49.71	47.00	44.64	42.58	40.76	39.14	37.70	36.41	35.25	34.21	33.24	32.33	
88.0"	59.53	52.40	49.58	47.13	44.98	43.09	41.41	39.92	38.58	37.39	36.29	35.25	34.27	
84.0"	62.83	55.40	52.45	49.90	47.66	45.70	43.96	42.41	41.03	39.77	38.58	37.47	36.41	
80.0"	66.53	58.75	55.68	53.02	50.69	48.65	46.84	45.24	43.78	42.41	41.13	39.92	38.78	
76.0"	70.69	62.54	59.33	56.55	54.13	52.00	50.13	48.43	46.84	45.35	43.96	42.65	41.41	
72.0"	75.40	66.86	63.49	60.59	58.06	55.85	53.86	52.00	50.27	48.65	47.13	45.70	44.35	
68.0"	80.79	71.81	68.29	65.25	62.62	60.25	58.06	56.02	54.13	52.35	50.69	49.13	47.66	
64.0"	87.00	77.55	73.86	70.69	67.86	65.25	62.83	60.59	58.50	56.55	54.73	53.02	51.41	
60.0"	94.25	84.30	80.43	77.00	73.86	70.96	68.29	65.80	63.49	61.34	59.33	57.45	55.68	
56.0"	102.82	92.33	88.13	84.30	80.79	77.55	74.57	71.81	69.24	66.86	64.63	62.54	60.59	
52.0"	113.10	101.85	97.12	92.80	88.85	85.22	81.88	78.79	75.93	73.26	70.78	68.46	66.29	
48.0"	125.67	113.10	107.71	102.82	98.35	94.25	90.48	87.00	83.78	80.79	78.00	75.40	72.97	
44.0"	141.01	126.55	120.37	114.77	109.67	105.01	100.72	96.77	93.12	89.73	86.58	83.65	80.91	
40.0"	150.00	142.86	135.72	129.26	123.38	118.02	113.10	108.58	104.40	100.53	96.94	93.60	90.48	
36.0"	150.00	150.00	150.00	147.12	140.28	134.04	128.34	123.10	118.27	113.81	109.67	105.82	102.24	
32.0"	150.00	150.00	150.00	150.00	150.00	150.00	147.52	141.38	135.72	130.50	125.67	121.18	117.00	
28.0"	150.00	150.00	150.00	150.00	150.00	150.00	150.00	150.00	150.00	150.00	146.33	141.01	136.06	
24.0"	150.00	150.00	150.00	150.00	150.00	150.00	150.00	150.00	150.00	150.00	150.00	150.00	150.00	
20.0"	150.00	150.00	150.00	150.00	150.00	150.00	150.00	150.00	150.00	150.00	150.00	150.00	150.00	

INSTRUCTIONS FOR USE OF THE MULLION LOAD TABLE:

1. DETERMINE THE DESIGN LOAD REQUIREMENT PER CHAPTER 16 OF THE FBC FOR THE PARTICULAR OPENING.
2. FOR THE PARTICULAR OPENING, DETERMINE THE TRIBUTARY WIDTH AND MULLION SPAN. REFERENCE THE SKETCHES ON THIS SHEET FOR MULLION SPAN AND TRIBUTARY WIDTH DETERMINATION.
3. IN THE FIRST COLUMN OF THE TABLE, LOCATE THE MULLION SPAN. IN THE FIRST ROW OF THE TABLE, LOCATE THE TRIBUTARY WIDTH. AT THE INTERSECTION OF THE ROW CONTAINING THE MULLION SPAN AND THE COLUMN CONTAINING THE TRIBUTARY WIDTH, READ THE MULLION LOAD RATING GIVEN IN PSF. THE MULLION LOAD RATING MUST BE EQUAL TO OR GREATER THAN THE DESIGN LOAD REQUIREMENT DETERMINED IN STEP 1 ABOVE.

L. F. SCHMIDT
FLORIDA PROFESSIONAL ENGINEER
No. 43409

Documents Prepared By: *[Signature]*
Lyndon F. Schmidt
P.E. No. 43409

RW
BUILDING CONSULTANTS, INC.
P.O. Box 230, Vairico, FL 33595
Phone No.: 813.659.9197
FBPE C.A. No. 9813

PRODUCT:	STRUCTURAL MULLION
PART OR ASSEMBLY:	MULLION LOAD TABLE: ANCHOR CLIP B4 (CONCRETE SCREWS)
DATE:	02/28/12
SCALE:	NTS
DWG. BY:	EW
CHK. BY:	LFS
DRAWING NO.:	FL-15267.3
SHEET	4 OF 7

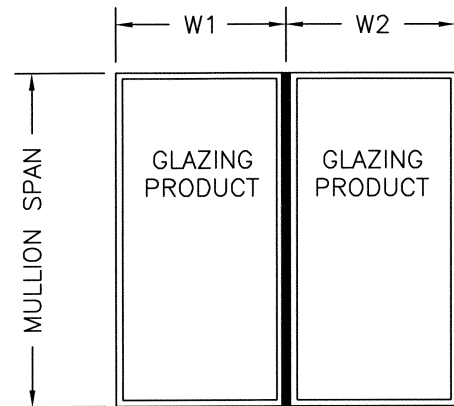

$$\text{TRIBUTARY WIDTH} = \frac{W1 + W2}{2}$$

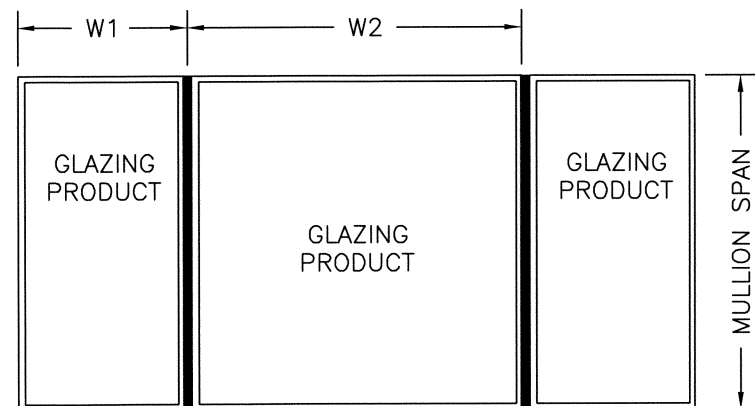

1" x 3" x .125" STEEL STRUCTURAL BEAM MULLION LOAD TABLE (PSF) - ANCHOR CLIP B4

WOOD SCREW	TRIBUTARY WIDTH													
	24.0"	28.0"	30.0"	32.0"	34.0"	36.0"	38.0"	40.0"	42.0"	44.0"	46.0"	48.0"	50.0"	
120.0"	40.13	34.73	32.46	30.43	28.64	27.05	25.63	24.35	23.19	22.13	21.17	20.29	19.48	
116.0"	43.42	37.22	34.74	32.57	30.65	28.95	27.43	26.05	24.81	23.69	22.66	21.71	20.84	
112.0"	45.24	39.57	37.27	34.94	32.88	31.05	29.42	27.95	26.62	25.41	24.30	23.29	22.36	
108.0"	47.13	41.25	38.92	36.88	35.09	33.40	31.64	30.06	28.63	27.33	26.14	25.05	24.05	
104.0"	49.17	43.09	40.67	38.56	36.71	35.07	33.61	32.31	30.87	29.47	28.19	27.01	25.93	
100.0"	51.41	45.09	42.58	40.39	38.47	36.78	35.27	33.93	32.72	31.64	30.49	29.22	28.05	
96.0"	53.86	47.29	44.68	42.41	40.42	38.67	37.11	35.72	34.47	33.35	32.33	31.42	30.43	
92.0"	56.55	49.71	47.00	44.64	42.58	40.76	39.14	37.70	36.41	35.25	34.21	33.24	32.33	
88.0"	59.53	52.40	49.58	47.13	44.98	43.09	41.41	39.92	38.58	37.39	36.29	35.25	34.27	
84.0"	62.83	55.40	52.45	49.90	47.66	45.70	43.96	42.41	41.03	39.77	38.58	37.47	36.41	
80.0"	66.53	58.75	55.68	53.02	50.69	48.65	46.84	45.24	43.78	42.41	41.13	39.92	38.78	
76.0"	70.69	62.54	59.33	56.55	54.13	52.00	50.13	48.43	46.84	45.35	43.96	42.65	41.41	
72.0"	75.40	66.86	63.49	60.59	58.06	55.85	53.86	52.00	50.27	48.65	47.13	45.70	44.35	
68.0"	80.79	71.81	68.29	65.25	62.62	60.25	58.06	56.02	54.13	52.35	50.69	49.13	47.66	
64.0"	87.00	77.55	73.86	70.69	67.86	65.25	62.83	60.59	58.50	56.55	54.73	53.02	51.41	
60.0"	94.25	84.30	80.43	77.00	73.86	70.96	68.29	65.80	63.49	61.34	59.33	57.45	55.68	
56.0"	102.82	92.33	88.13	84.30	80.79	77.55	74.57	71.81	69.24	66.86	64.63	62.54	60.59	
52.0"	113.10	101.85	97.12	92.80	88.85	85.22	81.88	78.79	75.93	73.26	70.78	68.46	66.29	
48.0"	125.67	113.10	107.71	102.82	98.35	94.25	90.48	87.00	83.78	80.79	78.00	75.40	72.97	
44.0"	141.01	126.55	120.37	114.77	109.67	105.01	100.72	96.77	93.12	89.73	86.58	83.65	80.91	
40.0"	150.00	142.86	135.72	129.26	123.38	118.02	113.10	108.58	104.40	100.53	96.94	93.60	90.48	
36.0"	150.00	150.00	150.00	147.12	140.28	134.04	128.34	123.10	118.27	113.81	109.67	105.82	102.24	
32.0"	150.00	150.00	150.00	150.00	150.00	150.00	147.52	141.38	135.72	130.50	125.67	121.18	117.00	
28.0"	150.00	150.00	150.00	150.00	150.00	150.00	150.00	150.00	150.00	150.00	146.33	141.01	136.06	
24.0"	150.00	150.00	150.00	150.00	150.00	150.00	150.00	150.00	150.00	150.00	150.00	150.00	150.00	
20.0"	150.00	150.00	150.00	150.00	150.00	150.00	150.00	150.00	150.00	150.00	150.00	150.00	150.00	

INSTRUCTIONS FOR USE OF THE MULLION LOAD TABLE:

1. DETERMINE THE DESIGN LOAD REQUIREMENT PER CHAPTER 16 OF THE FBC FOR THE PARTICULAR OPENING.
2. FOR THE PARTICULAR OPENING, DETERMINE THE TRIBUTARY WIDTH AND MULLION SPAN. REFERENCE THE SKETCHES ON THIS SHEET FOR MULLION SPAN AND TRIBUTARY WIDTH DETERMINATION.
3. IN THE FIRST COLUMN OF THE TABLE, LOCATE THE MULLION SPAN. IN THE FIRST ROW OF THE TABLE, LOCATE THE TRIBUTARY WIDTH. AT THE INTERSECTION OF THE ROW CONTAINING THE MULLION SPAN AND THE COLUMN CONTAINING THE TRIBUTARY WIDTH, READ THE MULLION LOAD RATING GIVEN IN PSF. THE MULLION LOAD RATING MUST BE EQUAL TO OR GREATER THAN THE DESIGN LOAD REQUIREMENT DETERMINED IN STEP 1 ABOVE.

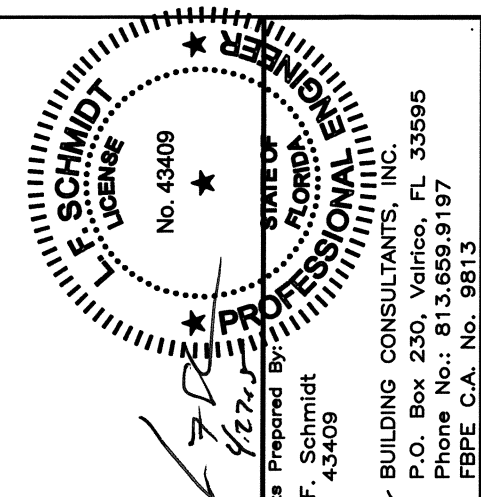

Documents Prepared By:
Lyndon F. Schmidt
P.E. No. 43409

RW BUILDING CONSULTANTS, INC.
P.O. Box 230, Valrico, FL 33595
Phone No.: 813.659.9197
FBPE C.A. No. 9813

PRODUCT:	STRUCTURAL MULLION
PART OR ASSEMBLY:	MULLION LOAD TABLE; ANCHOR CLIP B4 (WOOD SCREWS)
DATE:	02/28/12
SCALE:	NTS
DWG. BY:	EW
CHK. BY:	LFS
DRAWING NO.:	FL-15267.3
SHEET	5 OF 7

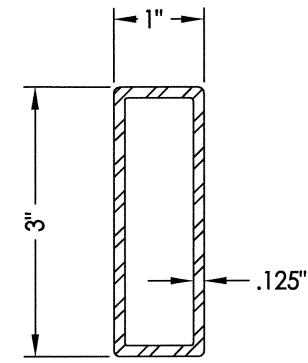

1" x 3" x 1/8" STEEL MULLION
ASTM A36 STEEL

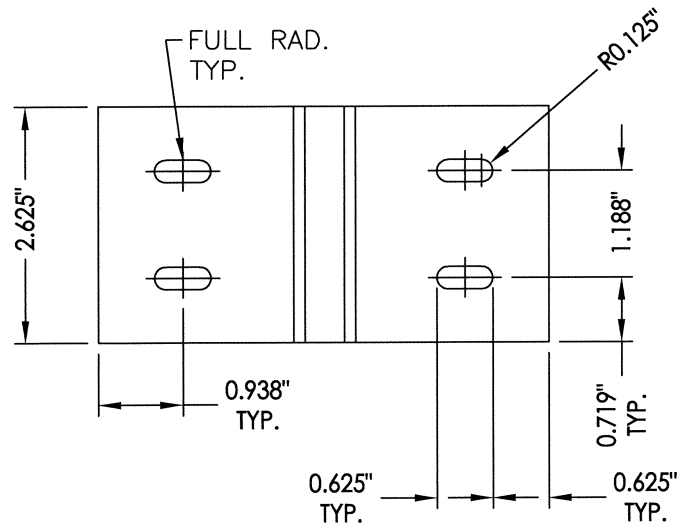
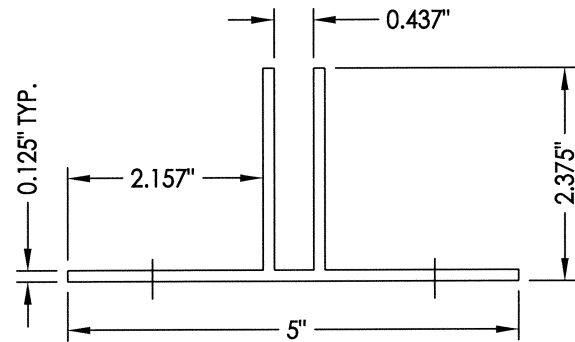

MULL CLIP - F2
ALUMINUM (6063-T6)

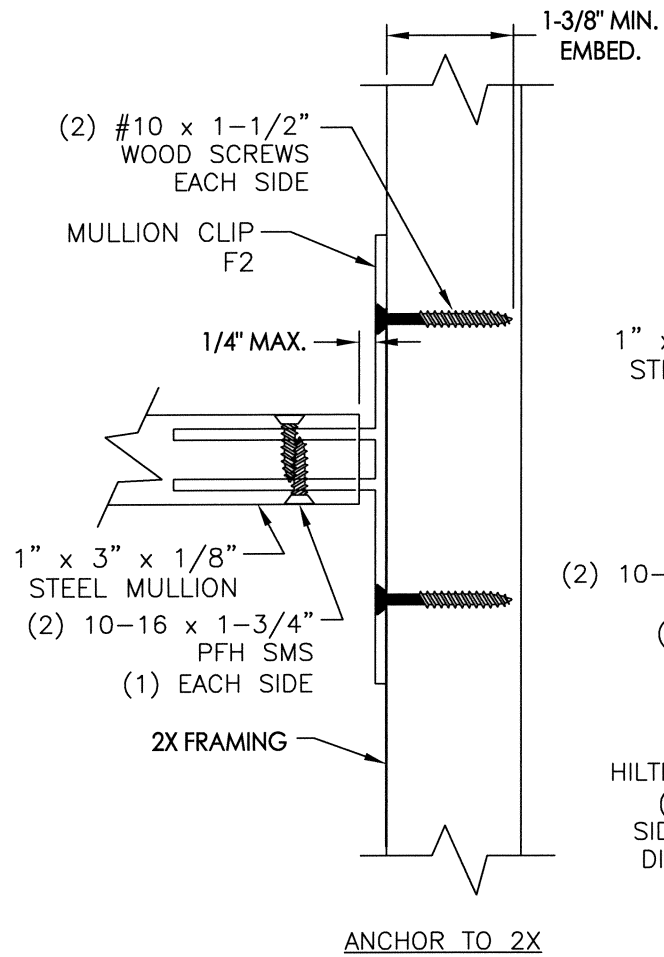

ANCHOR TO 2X

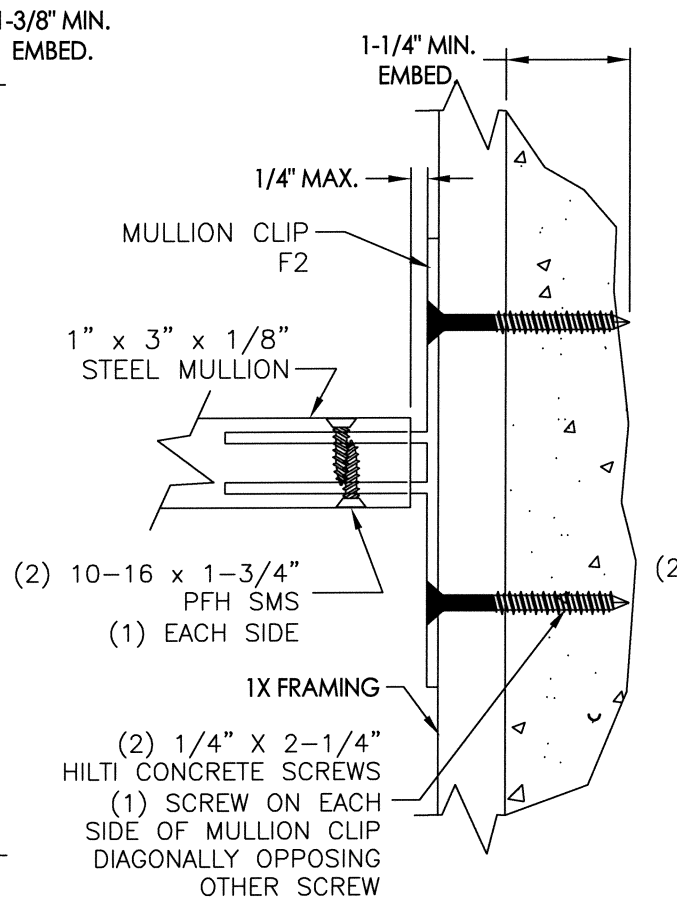

ANCHOR THROUGH 1X BUCK
USING 1/4" X 2-1/4"
HILTI CONCRETE SCREWS

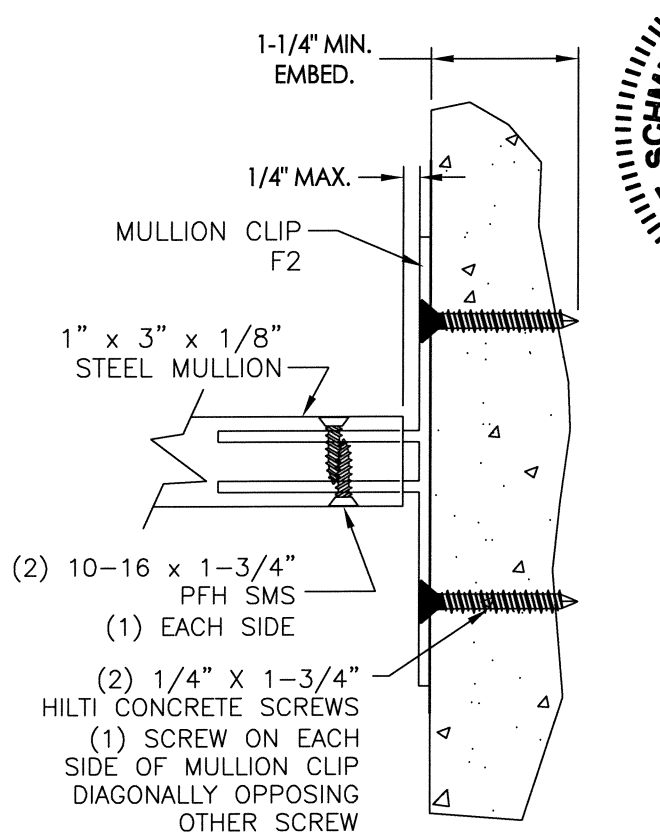

ANCHOR TO MASONRY
USING 1/4" X 1-3/4"
HILTI CONCRETE SCREWS

DISSIMILAR METALS THAT COME IN CONTACT MUST BE PAINTED TO AVOID CORROSION.

MULLION ANCHOR BRACKET ANCHOR SCHEDULE				
ANCHOR	SUBSTRATE	EMBEDMENT (MIN.)	EDGE DISTANCE (MIN.)	CENTER-TO-CENTER SPACING (MIN.)
#10 PFH WOOD SCREW	WOOD	1-3/8"	1"	1"
SELF-DRILLING SHEET METAL SCREW	STEEL	A MIN. OF 3 THREADS SHALL PROTRUDE COMPLETELY THROUGH THE STEEL SUBSTRATE	1"	1-1/8"
1/4" Ø PFH HILTI KWIK-CON II+	HOLLOW BLOCK	1-1/4"	2-1/2"	3"
	CONCRETE	1-1/4"	2-1/2"	3"

WOOD FRAMING (S.G. >= 0.42)
SHEET METAL SCREWS (SAE GRADE 5 MIN.): HILTI KWIK-FLEX or ELCO DRIL-FLEX
CONCRETE CONFORMING TO ACI 301 (3,000 PSI MIN.) OR HOLLOW BLOCK CONFORMING TO ASTM C90

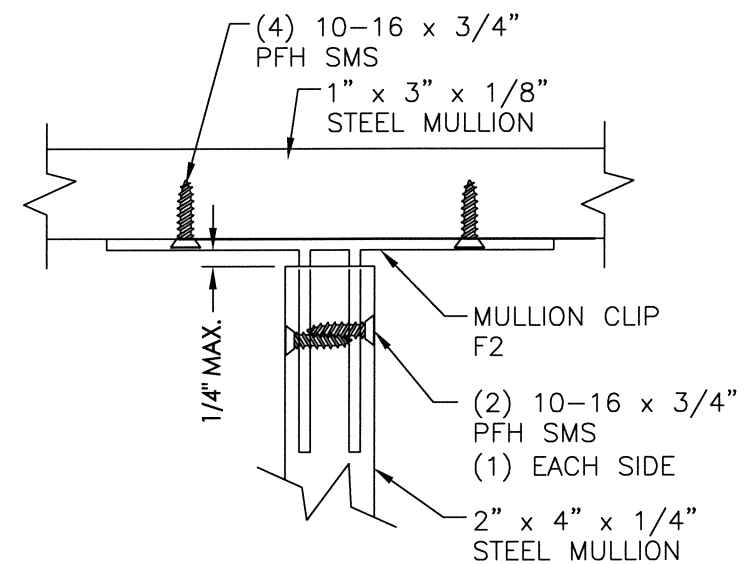

MULLION TO MULLION ANCHORING

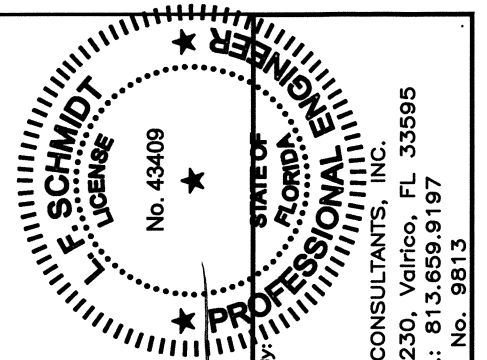

Documents Prepared By:
Lyndon F. Schmidt
P.E. No. 43409
RW BUILDING CONSULTANTS, INC.
P.O. Box 230, Valrico, FL 33595
Phone No.: 813.659.9197
FBPE C.A. No. 9813

PRODUCT:	STRUCTURAL MULLION
PART OR ASSEMBLY:	ANCHOR CLIP F2: ANCHORING DETAILS

NO.	DATE	REVISIONS
1	4/17/15	UPDATE TO 5TH ED. (2014) FBC

DATE:	02/28/12
SCALE:	NTS
DWG. BY:	EW
CHK. BY:	LFS
DRAWING NO.:	FL-15267.3
SHEET	6 OF 7

