

Pocket Interlock Adjustment Instructions for:

- **Product Series** - Big Doors
- **Product Type** - MultiGlide™ Door
- **Frame Configuration** - Pocket

Read these instructions and the Product Safety Information before starting procedure.

Tools Needed



Safety Glasses

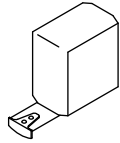

Tape Measure



#2 Phillips Bit

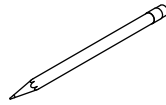

Pencil

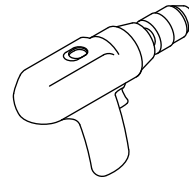

Drill/Driver



3/32"
Drill Bit

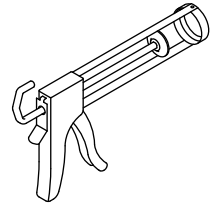

Caulking Gun

Supplies Needed

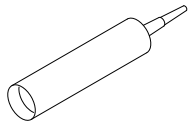

Sealant

Safety Information

WARNING

- Windows and doors can be heavy. Use safe lifting techniques and a reasonable number of people with enough strength to lift, carry, and install window and door products. Heavier windows and doors will require mechanical assistance. Failure to do so could result in injury, product or property damage.

WARNING

- Windows and doors have small parts (e.g. hole plugs, operator spline caps, fasteners, etc.). Small parts if swallowed could pose a choking hazard to young children. Dispose of unused, loose, or easily removed small parts. Failure to do so could result in injury.

WARNING

- Follow manufacturers' instructions for hand and power tools. Always wear safety glasses. Failure to do so could result in injury, product or property damage.

Thank you for choosing Andersen.

1

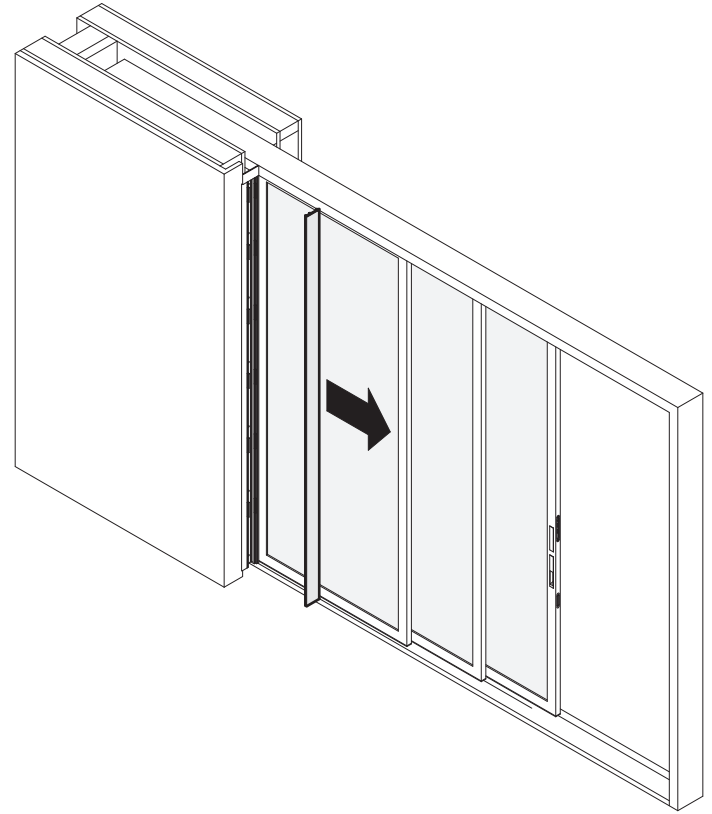
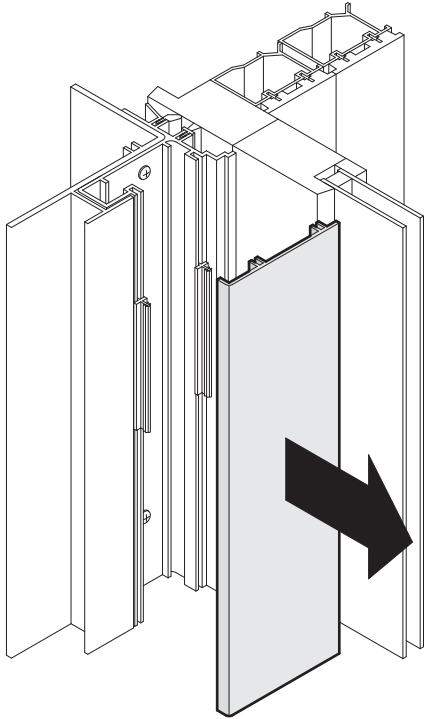

Remove the pocket interlock cover from the exterior.

2

IMPORTANT

- **DO NOT** remove top or bottom screws.

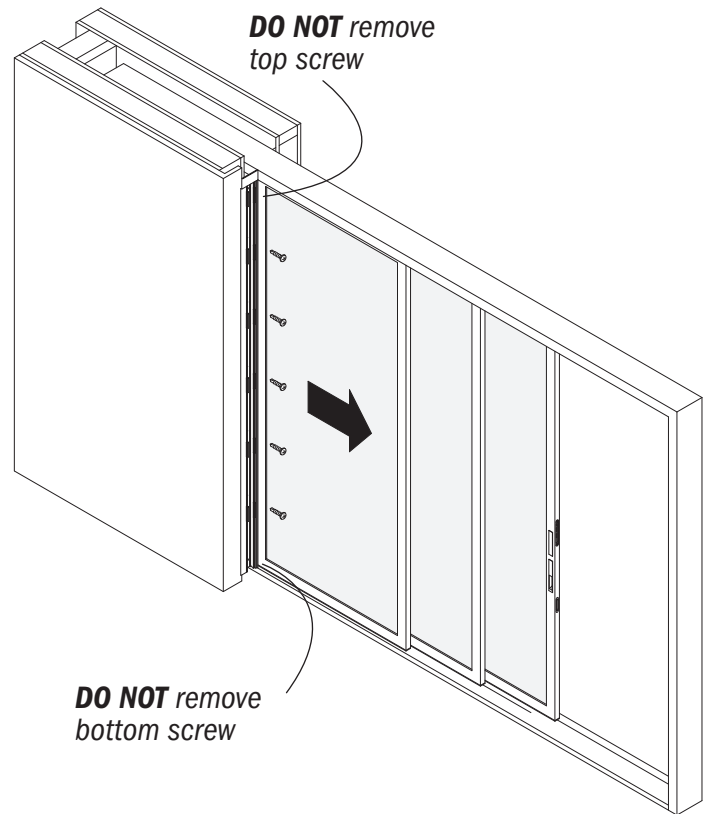
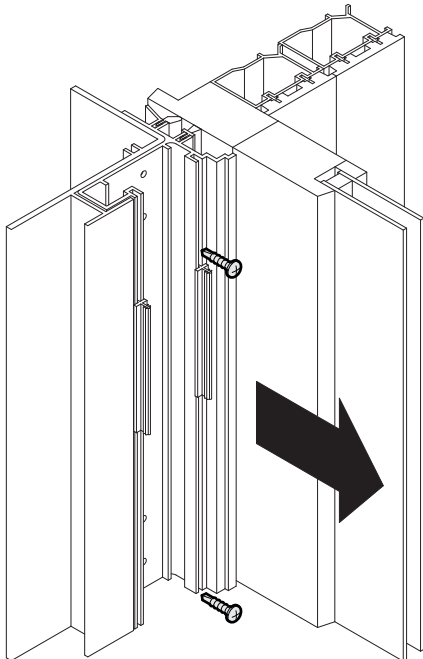

Remove the pocket interlock assembly screws, except for the top and bottom screws as shown. Save screws for reuse.

3

Equal reveal between panel and pocket interlock assembly

Pocket Interlock Assembly

Panel

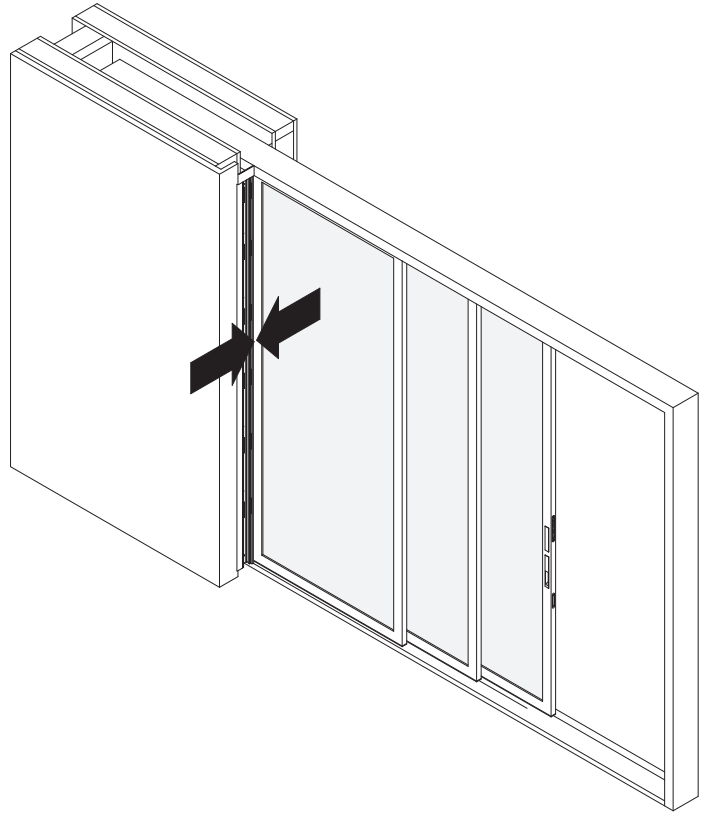
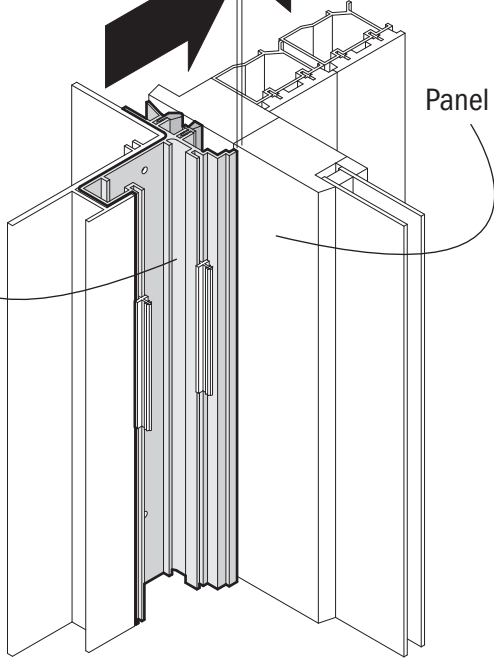

Adjust the pocket interlock assembly for a full length equal reveal.

4

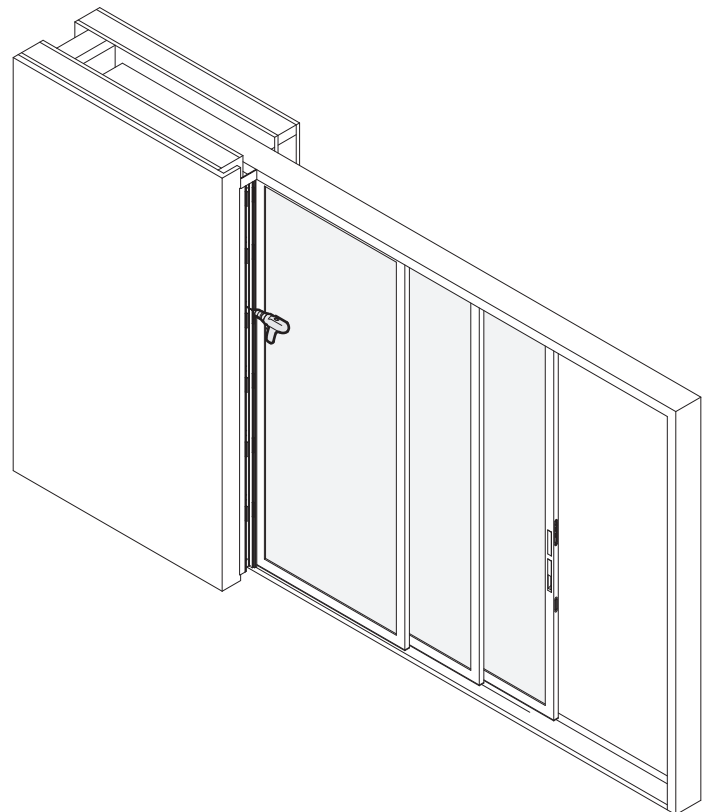
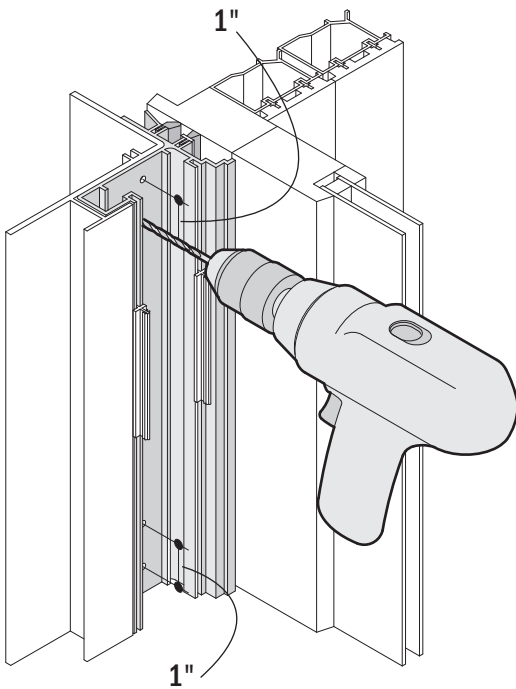

Measure, mark, and drill 3/32" pilot holes 1" directly below the existing screw holes, 3/4" deep.

5

IMPORTANT

- **DO NOT** over tighten screws.

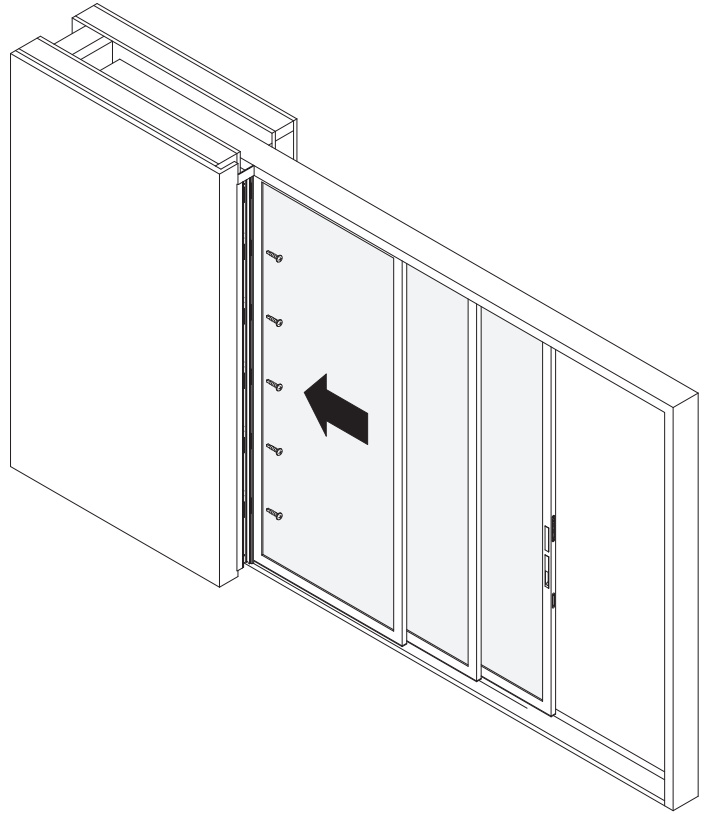
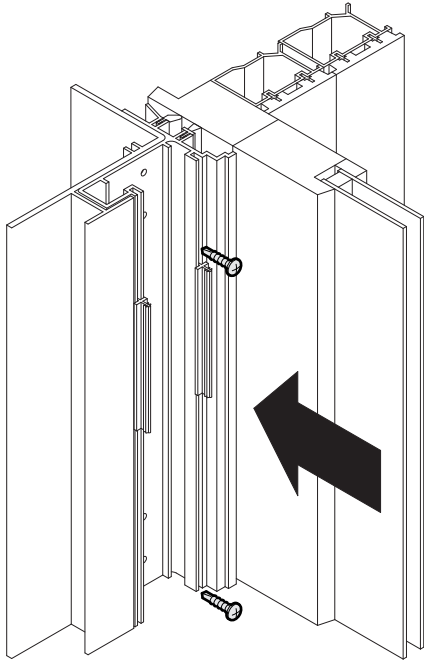

Refasten the pocket interlock assembly in the new pilot holes using the saved screws.

6

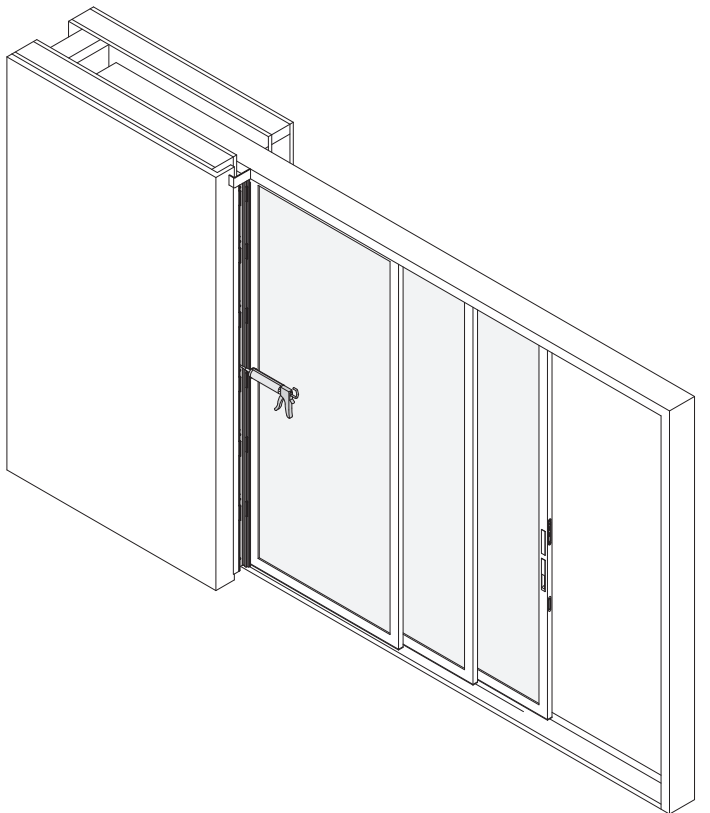
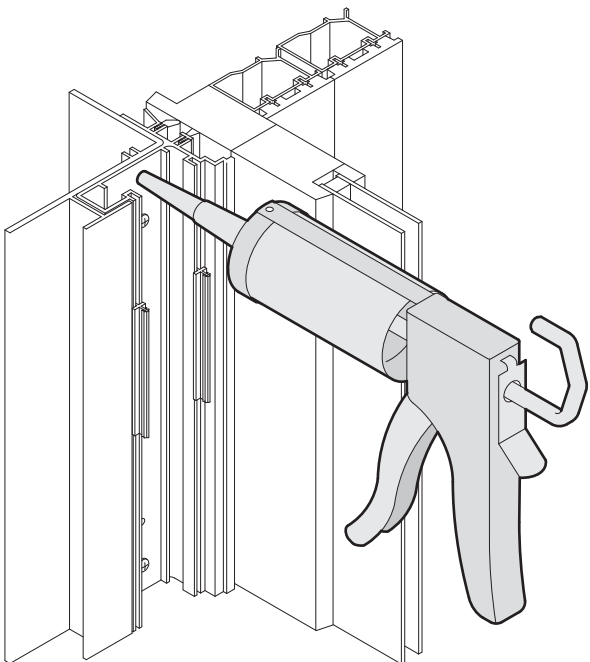

Apply sealant over the previous screw holes.

7

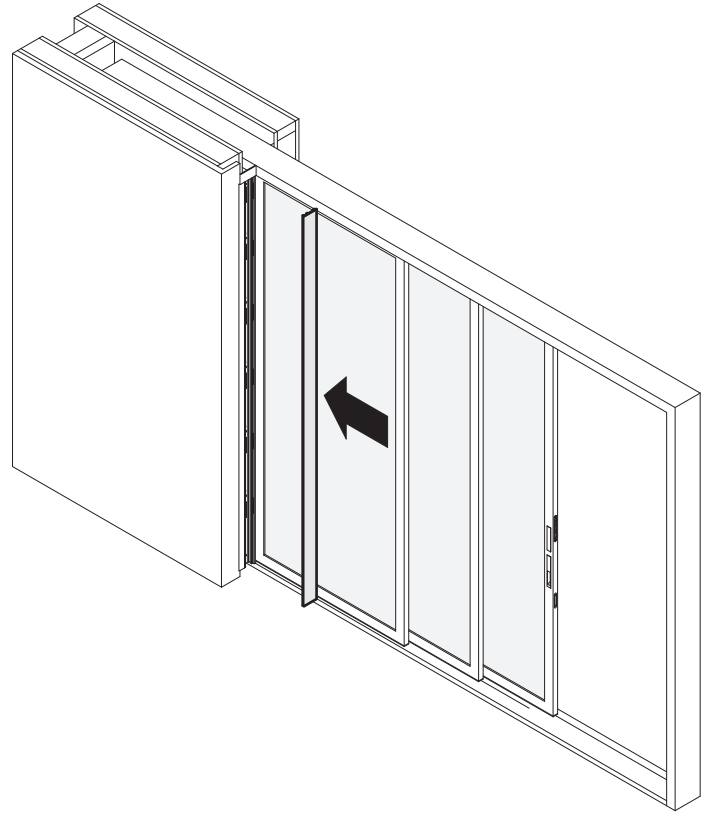
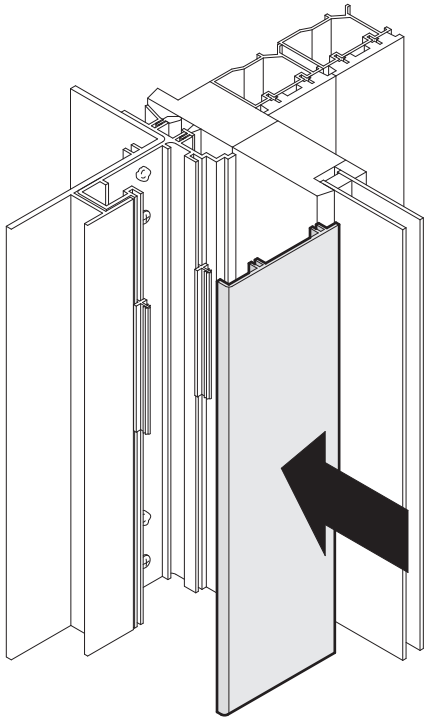

Reapply the pocket interlock cover using firm hand pressure.

Pocket interlock adjustment is complete.