

Double-Hung  
Half Circle Window

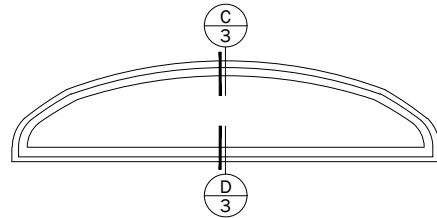

Elliptical Window

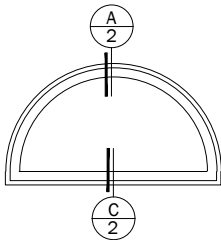

Casement  
Half Circle Window

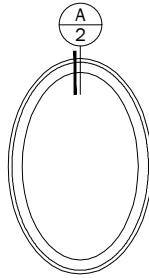

Oval Window

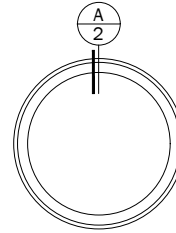

Circle Window

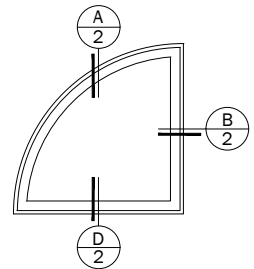

Quarter Circle Window

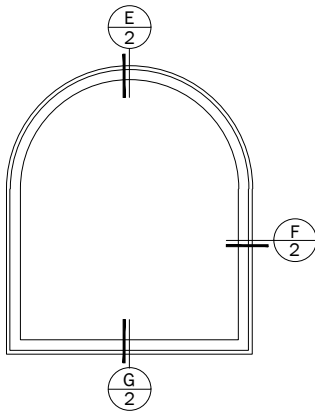

Springline™ Window

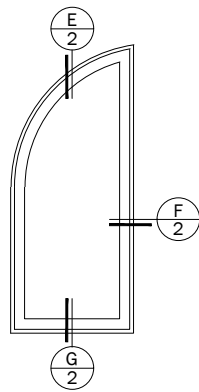

Springline™ Flanker Window

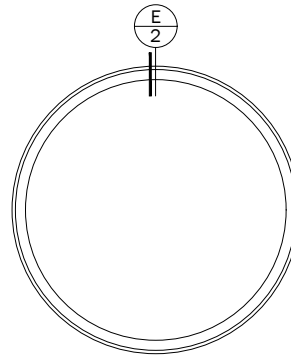

Monumental  
Circle Window

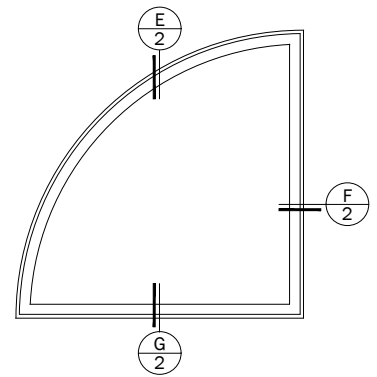

Monumental  
Quarter Circle Window

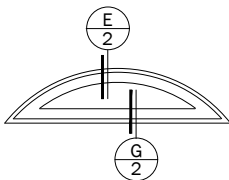

Eyebrow Window

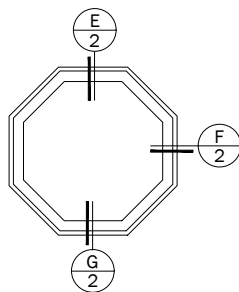

Octagon Window

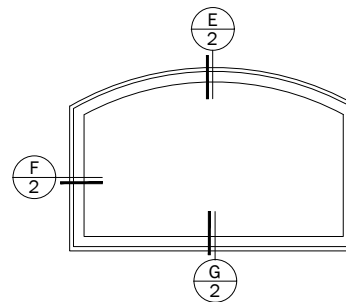

Arch Window

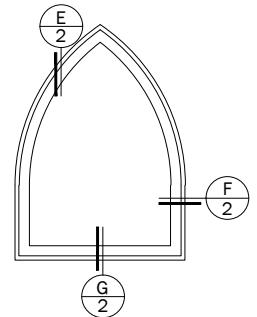

Gothic Window

**Notes:**

Details have been optimized for use in architectural software and do not match manufacturing specifications. Dimensions in parentheses are in millimeters.

See Pages 4 & 5 for Accessories

Date: 10/04/16  
Scale: None



# 400 SERIES

## Specialty Windows

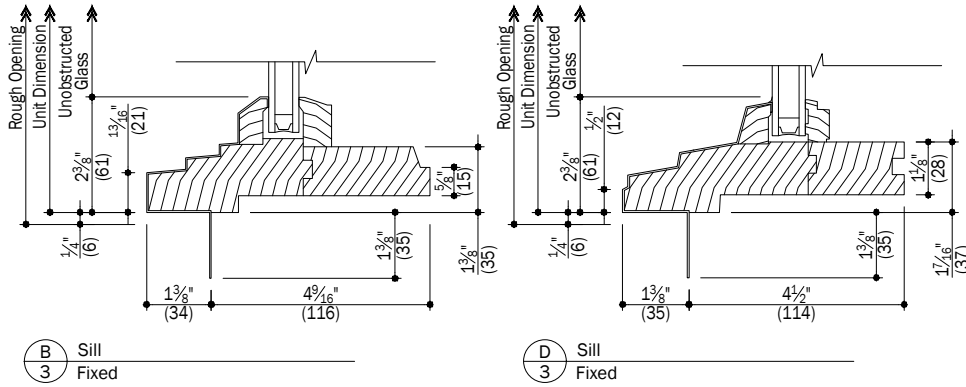
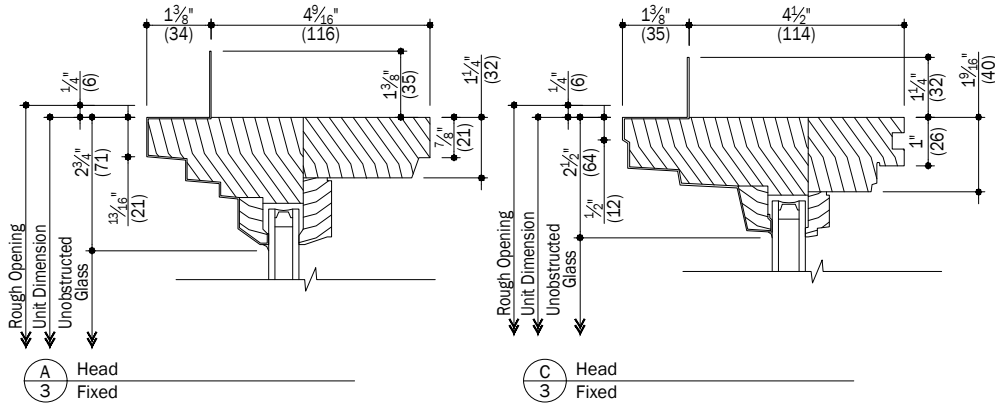

### Notes:

Details have been optimized for use in architectural software and do not match manufacturing specifications. Dimensions in parentheses are in millimeters.

See Pages 4 & 5 for Accessories

# 400 SERIES

## Specialty Windows Accessories

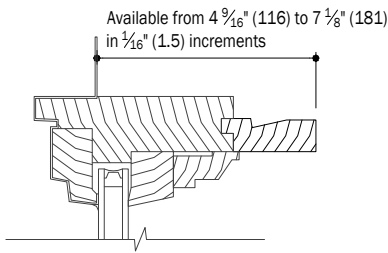

**A**  
4 Extension Jamb

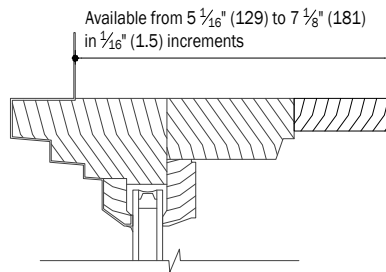

**D**  
4 Head Fixed

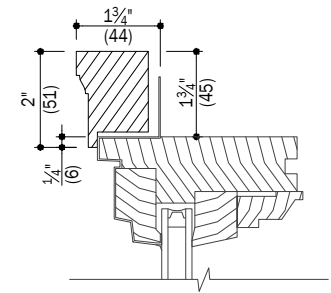

**G**  
4 2" Brick Mould  
Select specialty windows are available with exterior trim. Contact your Andersen supplier for details.

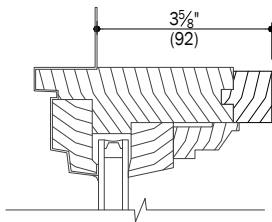

**B**  
4 Wide Drywall Return

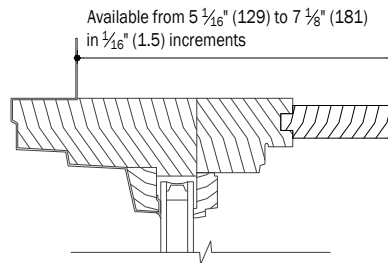

**E**  
4 Head Fixed

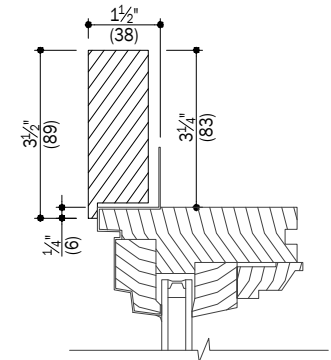

**H**  
4 3 1/2" Flat Casing  
Select specialty windows are available with exterior trim. Contact your Andersen supplier for details.

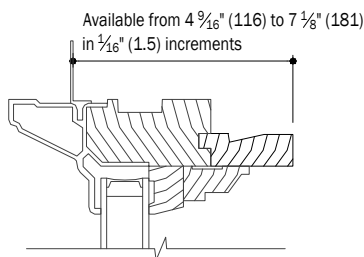

**C**  
4 Head Fixed

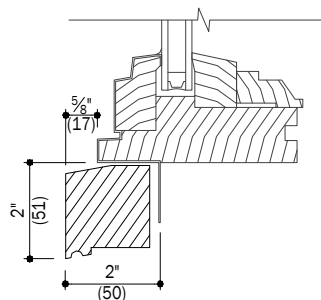

**F**  
4 Sill Nose  
Select specialty windows are available with exterior trim. Contact your Andersen supplier for details.

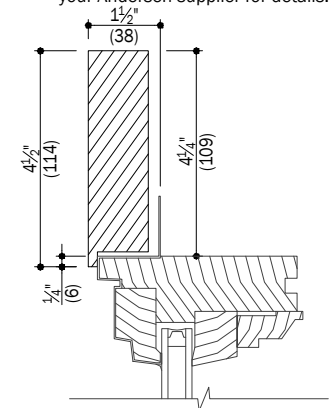

**J**  
4 4 1/2" Flat Casing  
Select specialty windows are available with exterior trim. Contact your Andersen supplier for details.

### Notes:

Details have been optimized for use in architectural software and do not match manufacturing specifications. Dimensions in parentheses are in millimeters.

# 400 SERIES

## Specialty Windows Accessories

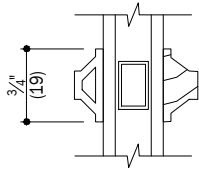

**A**  
5 3/4" Full Divided Light

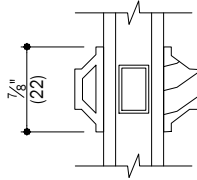

**E**  
5 7/8" Full Divided Light

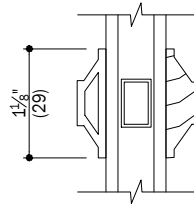

**H**  
5 1 1/8" Full Divided Light

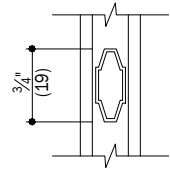

**L**  
5 3/4" Finelight

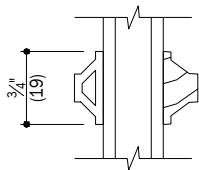

**B**  
5 3/4" Simulated Divided Light  
Removable interior is available

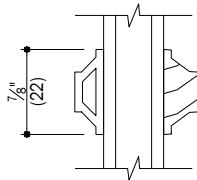

**F**  
5 7/8" Simulated Divided Light  
Removable interior is available

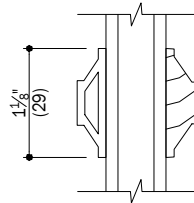

**J**  
5 1 1/8" Simulated Divided Light  
Removable interior is available

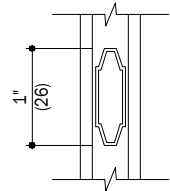

**M**  
5 1" Finelight

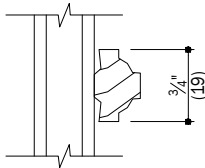

**C**  
5 3/4" Removable Interior Grille

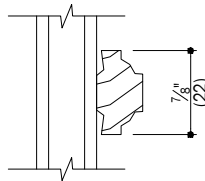

**G**  
5 7/8" Removable Interior Grille

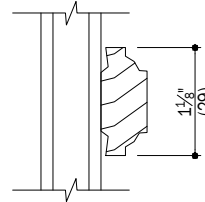

**K**  
5 1 1/8" Removable Interior Grille

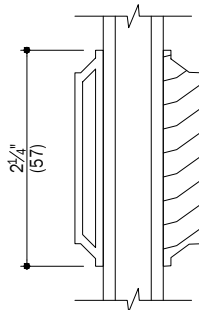

**D**  
6 2 1/4" Simulated Divided Light  
Simulated check rail

### Notes:

Details have been optimized for use in architectural software and do not match manufacturing specifications. Dimensions in parentheses are in millimeters.

Date: 10/04/16  
Scale: 6" (152) = 1' (305)